

GE Healthcare

Optima CT660

Pre-Installation Manual



OPERATING DOCUMENTATION



5368510-1EN
Rev 1

The information in this manual applies to the following GE Healthcare Optima CT Scanners:

- Optima CT660

The information in this manual does NOT apply to non-fixed (mobile) installations.

IMPORTANT PRECAUTIONS

LANGUAGE

ПРЕДУПРЕЖДЕНИ Е (BG)	<ul style="list-style-type: none">• ТОВА УПЪТВАНЕ ЗА РАБОТА Е НАЛИЧНО САМО НА АНГЛИЙСКИ ЕЗИК.• АКО ДОСТАВЧИКЪТ НА УСЛУГАТА НА КЛИЕНТА ИЗИСКА ЕЗИК, РАЗЛИЧЕН ОТ АНГЛИЙСКИ, ЗАДЪЛЖЕНИЕ НА КЛИЕНТА Е ДА ОСИГУРИ ПРЕВОД.• НЕ ИЗПОЛЗВАЙТЕ ОБОРУДВАНЕТО ПРЕДИ ДА СТЕ СЕ КОНСУЛТИРАЛИ И РАЗБРАЛИ УПЪТВАНЕТО ЗА РАБОТА.• НЕСПАЗВАНЕТО НА ТОВА ПРЕДУПРЕЖДЕНИЕ МОЖЕ ДА ДОВЕДЕ ДО НАРАНЯВАНЕ НА ДОСТАВЧИКА НА УСЛУГАТА, ОПЕРАТОРА ИЛИ ПАЦИЕНТ В РЕЗУЛТАТ НА ТОКОВ УДАР ИЛИ МЕХАНИЧНА ИЛИ ДРУГА ОПАСНОСТ.
警告 (ZH-CN)	<ul style="list-style-type: none">• 本维修手册仅提供英文版本。• 如果维修服务提供商需要非英文版本，客户需自行提供翻译服务。• 未详细阅读和完全理解本维修手册之前，不得进行维修。• 忽略本警告可能对维修人员，操作员或患者造成触电、机械伤害或其他形式的伤害。
VÝSTRAHA (CS)	<ul style="list-style-type: none">• Tento provozní návod existuje pouze v anglickém jazyce.• V případě, že externí služba zákazníkům potřebuje návod v jiném jazyce, je zajištění překladu do odpovídajícího jazyka úkolem zákazníka.• Nesnažte se o údržbu tohoto zařízení, aniž byste si přečetli tento provozní návod a pochopili jeho obsah.• V případě nedodržování této výstrahy může dojít k poranění pracovníka prodejního servisu, obslužného personálu nebo pacientů vlivem elektrického proudu, respektive vlivem mechanických či jiných rizik.
ADVARSEL (DA)	<ul style="list-style-type: none">• Denne servicemanual findes kun på engelsk.• Hvis en kundes tekniker har brug for et andet sprog end engelsk, er det kundens ansvar at sørge for oversættelse.• Forsøg ikke at servicere udstyret medmindre denne servicemanual har været konsulteret og er forstået.• Manglende overholdelse af denne advarsel kan medføre skade på grund af elektrisk, mekanisk eller anden fare for teknikerens, operatørens eller patientens.
WAARSCHUWING (NL)	<ul style="list-style-type: none">• Deze onderhoudshandleiding is enkel in het Engels verkrijgbaar.• Als het onderhoudspersoneel een andere taal vereist, dan is de klant verantwoordelijk voor de vertaling ervan.• Probeer de apparatuur niet te onderhouden voordat deze onderhoudshandleiding werd geraadpleegd en begrepen is.• Indien deze waarschuwing niet wordt opgevolgd, zou het onderhoudspersoneel, de operator of een patiënt gewond kunnen raken als gevolg van een elektrische schok, mechanische of andere gevaren.

WARNING (EN)	<ul style="list-style-type: none">• This Service Manual is available in English only.• If a customer's service provider requires a language other than English, it is the customer's responsibility to provide translation services.• Do not attempt to service the equipment unless this service manual has been consulted and is understood.• Failure to heed this warning may result in injury to the service provider, operator, or patient, from electric shock or from mechanical or other hazards.
HOIATUS (ET)	<ul style="list-style-type: none">• Käesolev teenindusjuhend on saadaval ainult inglise keeles.• Kui klienditeeninduse osutaja nõuab juhendit inglise keelest erinevas keeles, vastutab klient tõlketeenuse osutamise eest.• Ärge üritage seadmeid teenindada enne eelnevalt käesoleva teenindusjuhendiga tutvumist ja sellest aru saamist.• Käesoleva hoiatuse eiramine võib põhjustada teenuseosutaja, operaatori või patsiendi vigastamist elektrilöögi, mehaanilise või muu ohu tagajärjel.
VAROITUS (FI)	<ul style="list-style-type: none">• Tämä huolto-ohje on saatavilla vain englanniksi.• Jos asiakkaan huoltohenkilöstö vaatii muuta kuin englanninkielistä materiaalia, tarvittavan käännöksen hankkiminen on asiakkaan vastuulla.• Älä yritä korjata laitteistoa ennen kuin olet varmasti lukenut ja ymmärtänyt tämän huolto-ohjeen.• Mikäli tätä varoitusta ei noudateta, seurauksena voi olla huoltohenkilöstön, laitteiston käyttäjän tai potilaan vahingoittuminen sähköiskun, mekaanisen vian tai muun vaaratilanteen vuoksi.
ATTENTION (FR)	<ul style="list-style-type: none">• Ce manuel de service n'est disponible qu'en anglais.• Si le technicien du client a besoin de ce manuel dans une autre langue que l'anglais, c'est au client qu'il incombe de le faire traduire.• Ne pas tenter d'intervenir sur les équipements tant que le manuel service n'a pas été consulté et compris• Le non-respect de cet avertissement peut entraîner chez le technicien, l'opérateur ou le patient des blessures dues à des dangers électriques, mécaniques ou autres.
WARNUNG (DE)	<ul style="list-style-type: none">• Diese Serviceanleitung existiert nur in Englischer Sprache.• Falls ein fremder Kundendienst eine andere Sprache benötigt, ist es aufgabe des Kunden für eine Entsprechende Übersetzung zu sorgen.• Versuchen Sie nicht diese Anlage zu warten, ohne diese Serviceanleitung gelesen und verstanden zu haben.• Wird diese Warnung nicht beachtet, so kann es zu Verletzungen des Kundendiensttechnikers, des Bedieners oder des Patienten durch Stromschläge, Mechanische oder Sonstige gefahren kommen.
ΠΡΟΕΙΔΟΠΟΙΗΣΗ (EL)	<ul style="list-style-type: none">• Το παρόν εγχειρίδιο σέρβις διατίθεται στα αγγλικά μόνο.• Εάν το άτομο παροχής σέρβις ενός πελάτη απαιτεί το παρόν εγχειρίδιο σε γλώσσα εκτός των αγγλικών, αποτελεί ευθύνη του πελάτη να παρέχει υπηρεσίες μετάφρασης.• Μην επιχειρήσετε την εκτέλεση εργασιών σέρβις στον εξοπλισμό εκτός εαν έχετε συμβουλευτεί και έχετε κατανοήσει το παρόν εγχειρίδιο σέρβις.• Εάν δε λάβετε υπόψη την προειδοποίηση αυτή, ενδέχεται να προκληθεί τραυματισμός στο άτομο παροχής σέρβις, στο χειριστή ή στον ασθενή από ηλεκτροπληξία, μηχανικούς ή άλλους κινδύνους.

<p>FIGYELMEZTETÉS (HU)</p>	<ul style="list-style-type: none"> • Ezen karbantartási kézikönyv kizárólag angol nyelven érhető el. • Ha a vevő szolgáltatója angoltól eltérő nyelvre tart igényt, akkor a vevő felelőssége a fordítás elkészítése. • Ne próbálja elkezdni használni a berendezést, amíg a karbantartási kézikönyvben leírtakat nem értelmezték. • Ezen figyelmeztetés figyelmen kívül hagyása a szolgáltató, működtető vagy a beteg áramütés, mechanikai vagy egyéb veszélyhelyzet miatti sérülését eredményezheti.
<p>AÐVÖRUN (IS)</p>	<ul style="list-style-type: none"> • Þessi þjónustuhandbók er eingöngu fánleg á ensku. • Ef að þjónustuveitandi viðskiptamanns þarfnast annas tungumáls en ensku, er það skylda viðskiptamanns að skaffa tungumálþjónustu. • Reynið ekki að afgreiða tækið nema að þessi þjónustuhandbók hefur verið skoðuð og skilin. • Brot á sinna þessari aðvörun getur leitt til meiðsla á þjónustuveitanda, stjórnanda eða sjúklings frá raflosti, vélrænu eða öðrum áhættum.
<p>AVVERTENZA (IT)</p>	<ul style="list-style-type: none"> • Il presente manuale di manutenzione è disponibile soltanto in inglese. • Se un addetto alla manutenzione richiede il manuale in una lingua diversa, il cliente è tenuto a provvedere direttamente alla traduzione. • Si proceda alla manutenzione dell'apparecchiatura solo dopo aver consultato il presente manuale ed averne compreso il contenuto • Il non rispetto della presente avvertenza potrebbe far compiere operazioni da cui derivino lesioni all'addetto, alla manutenzione, all'utilizzatore ed al paziente per folgorazione elettrica, per urti meccanici od altri rischi.
<p>警告 (JA)</p>	<ul style="list-style-type: none"> • このサービスマニュアルには英語版しかありません。 • サービスを担当される業者が英語以外の言語を要求される場合、翻訳作業はその業者の責任で行うものとさせていただきます。 • このサービスマニュアルを熟読し理解せずに、装置のサービスを行わないでください。 • この警告に従わない場合、サービスを担当される方、操作員あるいは患者さんが、感電や機械的又はその他の危険により負傷する可能性があります。
<p>경고 (KO)</p>	<ul style="list-style-type: none"> • 본 서비스 지침서는 영어로만 이용하실 수 있습니다. • 고객의 서비스 제공자가 영어 이외의 언어를 요구할 경우, 번역 서비스를 제공하는 것은 고객의 책임입니다. • 본 서비스 지침서를 참고했고 이해하지 않는 한은 해당 장비를 수리하려고 시도하지 마십시오. • 이 경고에 유의하지 않으면 전기 쇼크, 기계상의 혹은 다른 위험으로부터 서비스 제공자, 운영자 혹은 환자에게 위해를 가할 수 있습니다.
<p>BRDINJUMS (LV)</p>	<ul style="list-style-type: none"> • Ģī apkalpes rokasgrāmata ir pieejama tikai angļu valodā. • Ja klienta apkalpes sniedzējam nepieciešama informācija citā valodā, nevis angļu, klienta pienākums ir nodrošināt tulkošanu. • Neveiciet aprīkojuma apkalpi bez apkalpes rokasgrāmatas izlasīšanas un saprašanas. • Ģī brīdinājuma neievērošana var radīt elektriskās strāvas trieciena, mehānisku vai citu risku izraisītu traumu apkalpes sniedzējam, operatoram vai pacientam.

<p>ÁSPĖJIMAS (LT)</p>	<ul style="list-style-type: none"> • Šis eksploataavimo vadovas yra prieinamas tik anglų kalba. • Jei kliento paslaugų tiekėjas reikalauja vadovo kita kalba – ne anglų, numatyti vertimo paslaugas yra kliento atsakomybė. • Nemėginkite atlikti árangos techninės priežiūros, nebent atsiþvelgėte á šá eksploataavimo vadovà ir já supratote. • Jei neatkreipsite dėmesio á šá perspėjimą, galimi suþalojimai dėl elektros šoko, mechaninio ar kitų pavojų paslaugų tiekėjui, operatoriui ar pacientui.
<p>ADVARSEL (NO)</p>	<ul style="list-style-type: none"> • Denne servicehåndboken finnes bare på engelsk. • Hvis kundens serviceleverandør trenger et annet språk, er det kundens ansvar å sørge for oversettelse. • Ikke forsøk å reparere utstyret uten at denne servicehåndboken er lest og forstått. • Manglende hensyn til denne advarselen kan føre til at serviceleverandøren, operatøren eller pasienten skades på grunn av elektrisk støt, mekaniske eller andre farer.
<p>OSTRZEŻENIE (PL)</p>	<ul style="list-style-type: none"> • Niniejszy podręcznik serwisowy dostępny jest jedynie w języku angielskim. • Jeśli dostawca usług klienta wymaga języka innego niż angielski, zapewnienie usługi tłumaczenia jest obowiązkiem klienta. • Nie próbować serwisować wyposażenia bez zapoznania się i zrozumienia niniejszego podręcznika serwisowego. • Niezastosowanie się do tego ostrzeżenia może spowodować urazy dostawcy usług, operatora lub pacjenta w wyniku porażenia elektrycznego, zagrożenia mechanicznego bądź innego.
<p>ATENÇÃO (PT)</p>	<ul style="list-style-type: none"> • Este manual de assistência técnica só se encontra disponível em inglês. • Se qualquer outro serviço de assistência técnica solicitar estes manuais noutra idioma, é da responsabilidade do cliente fornecer os serviços de tradução. • Não tente consertar o equipamento sem ter consultado e compreendido este manual de assistência técnica. • O não cumprimento deste aviso pode pôr em perigo a segurança do técnico, do operador ou do paciente devido a choques elétricos, mecânicos ou outros.
<p>ATENȚIE (RO)</p>	<ul style="list-style-type: none"> • Acest manual de service este disponibil numai în limba engleză. • Dacă un furnizor de servicii pentru clienți necesită o altă limbă decât cea engleză, este de datoria clientului să furnizeze o traducere. • Nu încercați să reparați echipamentul decât ulterior consultării și înțelegerii acestui manual de service. • Ignorarea acestui avertisment ar putea duce la rănirea depanatorului, operatorului sau pacientului în urma pericolelor de electrocutare, mecanice sau de altă natură.

ОСТОРОЖНО! (RU)	<ul style="list-style-type: none">• Данное руководство по обслуживанию предлагается только на английском языке.• Если сервисному персоналу клиента необходимо руководство не на английском, а на каком-то другом языке, клиенту следует самостоятельно обеспечить перевод.• Перед обслуживанием оборудования обязательно обратитесь к данному руководству и поймите изложенные в нем сведения.• Несоблюдение требований данного предупреждения может привести к тому, что специалист по обслуживанию, оператор или пациент получат удар электрическим током, механическую травму или другое повреждение.
UPOZORNENIE (SK)	<ul style="list-style-type: none">• Tento návod na obsluhu je k dispozícii len v angličtine.• Ak zákazníkovi poskytovateľ služieb vyžaduje iný jazyk ako angličtinu, poskytnutie prekladateľských služieb je zodpovednosťou zákazníka.• Nepokúšajte sa o obsluhu zariadenia skôr, ako si neprečítate návod na obsluhu a neporozumiete mu.• Zanedbanie tohto upozornenia môže vyústiť do zranenia poskytovateľa služieb, obsluhujúcej osoby alebo pacienta elektrickým prúdom, do mechanického alebo iného nebezpečenstva.
ATENCION (ES)	<ul style="list-style-type: none">• Este manual de servicio sólo existe en inglés.• Si el encargado de mantenimiento de un cliente necesita un idioma que no sea el inglés, el cliente deberá encargarse de la traducción del manual.• No se deberá dar servicio técnico al equipo, sin haber consultado y comprendido este manual de servicio.• La no observancia del presente aviso puede dar lugar a que el proveedor de servicios, el operador o el paciente sufran lesiones provocadas por causas eléctricas, mecánicas o de otra naturaleza.
VARNING (SV)	<ul style="list-style-type: none">• Den här servicehandboken finns bara tillgänglig på engelska.• Om en kunds servicetekniker har behov av ett annat språk än engelska ansvarar kunden för att tillhandahålla översättningstjänster.• Försök inte utföra service på utrustningen om du inte har läst och förstår den här servicehandboken.• Om du inte tar hänsyn till den här varningen kan det resultera i skador på serviceteknikern, operatören eller patienten till följd av elektriska stötar, mekaniska faror eller andra faror.
DIKKAT (TR)	<ul style="list-style-type: none">• Bu servis kilavuzunun sadece ingilizcesi mevcuttur.• Eğer müşteri teknisyeni bu kilavuzu ingilizce dışında bir başka lisandan talep ederse, bunu tercüme ettirmek müşteriye düşer.• Servis kilavuzunu okuyup anlamadan ekipmanlara müdahale etmeyiniz.• Bu uyarıya uyulmaması, elektrik, mekanik veya diğer tehlikelerden dolayı teknisyen, operatör veya hastanın yaralanmasına yol açabilir.

DAMAGE IN TRANSPORTATION

You should closely examine all packages at time of delivery. If you notice any damage, have the notation "Damage in Shipment" written on all copies of the freight or express bill before delivery is accepted or "signed for" by any General Electric representative or hospital receiving agent. Whether noted or concealed, you MUST report damage to the carrier immediately upon discovery and within 14 days after receipt, and you must hold the contents and containers for inspection by the carrier. A transportation company will not pay a claim for damage if you do not request an inspection within this 14-day period.

To file a report:

- Call 1-800-548-3366 and use option 8.
- Fill out a report on <http://egems.med.ge.com/edq/home.jsp>
- Contact your local service coordinator for more information on this process.

Rev. June 13, 2006

CERTIFIED ELECTRICAL CONTRACTOR STATEMENT

All electrical installations that are preliminary to positioning of the equipment at the site prepared for the equipment shall be performed by licensed electrical contractors. In addition, electrical feeds into the Power Distribution Unit shall be performed by licensed electrical contractors. Other connections between pieces of electrical equipment, calibrations and testing shall be performed by qualified GE Healthcare personnel. The products involved (and the accompanying electrical installations) are highly sophisticated, and special engineering competence is required. In performing all electrical work on these products, GE will use its own specially trained field engineers. All of GE's electrical work on these products will comply with the requirements of the applicable electrical codes.

The purchaser of GE equipment shall only utilize qualified personnel (i.e., GE's field engineers, personnel of third-party service companies with equivalent training, or licensed electricians) to perform electrical servicing on the equipment.

IMPORTANT...X-RAY PROTECTION

X-ray equipment if not properly used may cause injury. Accordingly, the instructions herein contained should be thoroughly read and understood by everyone who will use the equipment before you attempt to place this equipment in operation. The General Electric Company, Medical Systems Group, will be glad to assist and cooperate in placing this equipment in use.

Although this apparatus incorporates a high degree of protection against x-radiation other than the useful beam, no practical design of equipment can provide complete protection. Nor can any practical design compel the operator to take adequate precautions to prevent the possibility of any persons carelessly exposing themselves or others to radiation.

It is important that anyone having anything to do with x-radiation be properly trained and fully acquainted with the recommendations of the National Council on Radiation Protection and Measurements as published in NCRP Reports available from NCRP Publications, 7910 Woodmont Avenue, Room 1016, Bethesda, Maryland 20814, and of the International Commission on Radiation Protection, and take adequate steps to protect against injury.

The equipment is sold with the understanding that the General Electric Company, Medical Systems Group, its agents, and representatives have no responsibility for injury or damage which may result from improper use of the equipment.

Various protective materials and devices are available. It is urged that such materials or devices be used.

OMISSIONS & ERRORS

Customers: please contact your GE Healthcare Sales or Service representatives. GE personnel: please use the GE Healthcare Complaint Process to report all omissions, errors, and defects in this publication.

Revision History

Revision	Date	Reason for change
1	Mar.20, 2010	Initial Release

Table of Figures

Figure 2-1	Full construction site with completed radiology area.....	28
Figure 4-1	Regulatory Clearance Requirements for the Optima CT660 with GT1700V Table.....	38
Figure 4-2	Measuring Minimum Regulatory Clearances	41
Figure 5-1	Minimum Service Clearances	45
Figure 6-1	Suggested / Typical Room Size for Optima CT 660 w/ GT1700V Table	51
Figure 6-2	Suggested / Typical Room Size for Optima CT 660 w/ Lite Table	52
Figure 6-3	Minimum Room Size for Optima CT 660 w/ GT1700V Table	53
Figure 6-4	Minimum Room Size for Optima CT 660 w/ Lite Table	54
Figure 6-5	Short Footprint Calculation diagram.....	56
Figure 6-6	Typical Control Room Layout (Console with FWS Table).....	57
Figure 7-1	Gantry Dimensions with Covers.....	61
Figure 7-2	Lite Table and Gantry (Side View)	62
Figure 7-3	Gantry Tilted +30° (top) and -30° (bottom) - Lite Table Options.....	63
Figure 7-4	GT1700V Table and Gantry (Side View).....	64
Figure 7-5	Gantry Tilted +30° (top) and -30° (bottom) - GT1700V Table Options	65
Figure 7-6	Power Distribution Unit.....	66
Figure 7-7	Power Distribution Unit.....	66
Figure 7-8	Operator's Console	67
Figure 7-9	Freedom Workspace Table (part 5168666-3)	68
Figure 7-10	Cj Console with Optima Table.....	69
Figure 8-1	Center of Gravity for Boom-in-a-Room Kits, shown on the site print	72
Figure 8-2	Mounting hole pattern for Mavig ceiling pedestal base	73
Figure 8-3	Determining Floor Levelness	75
Figure 8-4	Allowable floor vibration in velocity units compared to ISO class A & B limits	76
Figure 8-5	Allowable floor vibration in acceleration units compared to ISO class A & B limits.....	77
Figure 8-6	Gantry and GT1700V Table Anchoring.....	81

Figure 8-7	Lite Table Anchoring.....	82
Figure 8-8	Console Center-of-Gravity	84
Figure 8-9	Gantry Center-of-Gravity	85
Figure 8-10	GT1700V Center-of-Gravity.....	85
Figure 8-11	Lite Table Center-of-Gravity	86
Figure 8-12	PDU Center-of-Gravity	87
Figure 9-1	HVAC Air Vent Placement in Scan Room	91
Figure 9-2	HVAC Air Vent Placement in Control Room.....	91
Figure 9-3	Sample Room Layout (Showing Approximate EMI Requirements).....	93
Figure 10-1	Typical Scatter Survey (Large Filter)	100
Figure 10-2	Typical Scatter Survey (Small Filter)	101
Figure 13-1	Interconnection Runs.....	117
Figure 13-2	TS6 X-Ray Warning Light Connections	120
Figure 13-3	TS6 Room Door Interlock Connections - Without a Door Interlock	120
Figure 13-4	TS6 Room Door Interlock Connections - With a Door Interlock	120
Figure 14-1	Gantry with Shipping Dollies and Side Rails.....	124
Figure 15-1	Proper Gantry Strap Location	130

Table of Tables

Table 1-1	Locations of Site Requirement Information in this manual.....	22
Table 1-2	Schedule Date Commitments	23
Table 1-3	General Site Planning	24
Table 1-4	Equipment Compatibility	24
Table 1-5	Network Connections.....	25
Table 1-6	Miscellaneous Tasks.....	25
Table 4-1	Console . Minimum workspace Clearances	39
Table 4-2	Minimum Workspace Clearances	39
Table 4-3	Gantry . Minimum Workspace Clearances.....	40
Table 4-4	Table . Minimum Workspace Clearances	40
Table 5-1	Equipment Stored in Storage Cabinet.....	48
Table 6-1	Scan Room Size Dimensions.....	49
Table 7-1	Minimum Dimensions and Operational Clearances	60
Table 8-1	CRITICAL SPECIFICATIONS for Floor Levelness	74
Table 8-2	Optima CT660 Component Weight and Floor Loading Data	78
Table 8-3	GE-Supplied Anchor Specifications	80
Table 8-4	Table and Gantry Anchoring Requirements.....	80
Table 9-1	System Temperature Limits	89
Table 9-2	System Humidity Limits.....	89
Table 9-3	System Heat Output.....	90
Table 9-4	Electromagnetic Emissions	94
Table 9-5	Electromagnetic Immunity.....	95
Table 9-6	Recommended Separation Distances.....	97
Table 10-1	Shielding Requirements Scaling	99
Table 12-1	Nominal Line Voltage Ranges.....	107

Table 12-2	Minimum Feeder Wire Size	108
Table 12-3	Minimum Feeder Wire Size	108
Table 12-4	Minimum Sub-Feeder Wire Size.....	108
Table 12-5	Minimum Sub-Feeder Wire Size.....	108
Table 12-6	Nominal Line Voltage Ranges	109
Table 12-7	Minimum Feeder Wire Size	109
Table 12-8	Minimum Feeder Wire Size	109
Table 12-9	Minimum Sub-Feeder Wire Size.....	110
Table 12-10	Minimum Sub-Feeder Wire Size.....	110
Table 13-1	Component Designators.....	111
Table 13-2	GE Healthcare Supplied Cables (Standard Run) - UL Information.....	112
Table 13-3	GE Healthcare Supplied Cables (Option Run) - UL Information.....	113
Table 13-4	GEMS Supplied Cables for Options - UL Information.....	114
Table 13-5	UPS Wiring Cables.....	115
Table 13-6	A1 UPS.....	115
Table 13-7	Runs 1, 2, 3, 4 and 5 Connections	116
Table 13-8	FUSE KIT Optima CT660 (5371451-2 BOM, rev x).....	118
Table 13-9	Contractor-Supplied Components	119
Table 14-1	Size of Gantry & Dollies, with and without Side Rails.....	124
Table 14-2	GT Table Dimensions with dollies	125

Table of Contents

Chapter 1

Introduction	21
Section 1.0:What is Pre-Installation?	21
Section 2.0:What is Pre-Installation Work?	21
Section 3.0:Pre-Installation Tools	21
3.1 Customer Pre-Installation Task	22
3.1.1 Pre-Installation Manual Guide	22
Section 4.0:Customer Pre-Installation Tasks	23

Chapter 2

Installation Types	27
Section 1.0:Determining Your Installation Type	27
1.1 How to Determine the Best Installation Type for Your Site.....	27
1.2 Typical Installations	27
1.3 Construction Site Installations	27
1.3.1 Full Construction Site with Completed Radiology Area	28
1.3.2 Full Construction Site with Limited Delivery Access	28
1.4 Relocatable Building Installations	28
1.5 Upgrade Installations	29
1.6 Quick Installations.....	29
1.6.1 Requirements	29
1.6.2 Restrictions	29
1.7 Two-Step (Temporary) Installations.....	30

Chapter 3

System Siting Requirements	31
Section 1.0:System Siting Requirements	31
Section 2.0:Customer System Siting Requirements	32
2.1 Regulatory Requirements	32
2.2 Electrical	32
2.3 Structural	33
2.3.1 Air / Dust Quality	33
2.3.2 Enviromental Influences	33
2.3.3 Finished Floor Requirements.....	33
2.3.4 Finished Walls	34
2.4 Radiation Protection	34
2.5 Environmental.....	34
2.6 Options	35
2.7 Clearances.....	35
2.8 Network.....	35
2.9 Chemical Contamination.....	35
2.10 Delivery.....	35

Section 3.0:Site Readiness	36
3.1 Pre-Installation Tasks.....	36
3.1.1 Pre-Installation Delivery Tasks.....	36
3.1.2 Site Review with Customer	36
 Chapter 4	
Regulatory Requirements	37
 Section 1.0:Regulatory Clearances.....	37
1.1 Regulations	37
1.2 Clearance Requirements	37
1.2.1 Minimum Regulatory Workspace Clearances by Major Subsystem	39
1.3 How to Measure	41
1.4 NEC Conduit and Duct Fill Rate.....	42
 Section 2.0:Terms and Definitions.....	43
 Chapter 5	
Service Clearance Requirements	45
 Section 1.0:Service Clearance Requirements.....	45
 Section 2.0:Service Clearances for Single Service Engineer.....	46
2.1 Cover Removal	46
2.2 Power Distribution Unit (PDU).....	46
2.3 Console	47
2.4 Storage Cabinet	48
 Chapter 6	
Room Sizes.....	49
 Section 1.0:Room Dimensions	49
1.1 Suggested Room Size	49
1.2 Typical Room Size	49
1.3 Minimum Room Size	49
 Section 2.0:Suggested and Typical Room Layouts	51
 Section 3.0:Minimum Room Layouts.....	53
 Section 4.0:Short Footprint Considerations	55
4.1 Instruction of using Short Footprint function.....	55
 Section 5.0:Control Room Considerations	57
5.1 Typical Control Room Layout.....	57
5.1.1 Console Considerations	57
 Section 6.0:Patient Environment.....	58

Chapter 7
System Component Dimensions 59

Section 1.0:Minimum Operating Clearances 59

- 1.1 Ceiling Pedestal Mount Installation..... 59
- 1.2 Injector Control Installation 59
- 1.3 System Operational Clearances 60

Section 2.0:Component Dimensions..... 61

- 2.1 Gantry Dimensions 61
- 2.2 Table and Gantry Dimensions (with Lite Table)..... 62
- 2.3 Table and Gantry Dimensions (with GT1700V Table) 64
- 2.4 Power Distribution Unit Dimensions (PDU-80) 66
- 2.5 Console Dimensions..... 67

Chapter 8
Structural and Mounting Requirements 71

Section 1.0:Overview 71

- 1.1 Importance of Meeting Structural Requirements 71
 - 1.1.1 Levelness, Vibration, and Floor Loading 71
 - 1.1.2 Seismic Loading 71
 - 1.1.3 Anchoring..... 71

Section 2.0:Ceiling Requirements 71

- 2.1 Mounting Plate..... 72
- 2.2 Pedestal Length Requirement 73
- 2.3 Electrical Box Requirement 74

Section 3.0:Minimum Floor Requirements 74

- 3.1 Floor Levelness Specifications 74
 - 3.1.1 Critical Specifications..... 74
 - 3.1.2 Floor Levelness Guidelines 74
 - 3.1.3 Measuring Floor Levelness..... 74
- 3.2 Walls..... 75
 - 3.2.1 Scan Window 75
- 3.3 Floor Vibration Specifications 76
 - 3.3.1 Requirements 76
 - 3.3.2 Sources of Floor Vibration 77

Section 4.0:Floor Loading and Component Weights..... 78

- 4.1 Floor Loading and Anchoring Guidelines..... 79

Section 5.0:GE-Supplied Anchoring..... 79

- 5.1 Specifications of GE-supplied Anchors..... 80
- 5.2 Requirements for Using GE-supplied Anchors 80

Section 6.0:Seismic Mounting 83

- 6.1 Overview..... 83
- 6.2 Center-of-Gravity Information 83

Chapter 9
Environmental Requirements 89

- Section 1.0:Temperature and Humidity Specifications..... 89**
 - 1.1 Temperature (Scan and Control Rooms) 89
 - 1.2 Humidity (Scan Room & Control Room) 89
 - 1.3 Other Guidelines 89
- Section 2.0:Cooling Requirements 90**
- Section 3.0:Altitude 91**
- Section 4.0:Electro-Magnetic Interference (EMI) 92**
 - 4.1 Gantry 92
 - 4.2 Console / Computer Equipment 92
 - 4.3 PDU..... 92
 - 4.4 EMI Reduction..... 92
 - 4.5 Equipment EMI "Envelopes" 93
- Section 5.0:Electro-Magnetic Compatibility (EMC)
(Reference IEC 60601-1-2)..... 94**
 - 5.1 General Scope 94
 - 5.2 Electromagnetic Emission (Reference IEC 60601-1-2 6.8.3.201) 94
 - 5.3 Electromagnetic Immunity (Reference IEC 60601-1-2 6.8.3.201) 95
 - 5.4 Installation Requirements and Environment Control..... 97
 - 5.4.1 Cable Shielding and Grounding 97

Chapter 10
Radiation Protection Requirements 99

- Section 1.0:Shielding Requirements 99**

Chapter 11
Network Requirements 103

- Section 1.0:Network Connections..... 103**
 - 1.1 Network Type 103
 - 1.2 Network Speed..... 103
 - 1.3 Network Cable Routing 103
- Section 2.0:Customer Broadband Responsibilities 103**
 - 2.1 Contact GE to Find Zone Broadband Specialist 103
 - 2.2 Provide GE with IT Contact Information for the Site 104

Chapter 12
Power Requirements 105

- Section 1.0:Introduction..... 105**
- Section 2.0:System Input Power 105**
 - 2.1 Power Source Configuration 105
 - 2.2 Rating..... 105

2.3 Regulation..... 106
 2.4 Phase Imbalance 106
 2.5 Sags, Surges and Transients 106
 2.6 Grounding..... 106
Section 3.0:Recommended Power Distribution System..... 107
 3.1 Using a Dedicated Distribution Transformer (Recommended) 107
 3.2 Using an Existing Distribution Transformer 107
 3.3 System Power Requirements 107

Chapter 13

Interconnection Data..... 111
Section 1.0:Introduction 111
Section 2.0:Component Designators 111
Section 3.0:Interconnect Runs, Wiring and Cables 112
 3.1 GE Healthcare Supplied (Standard Length 5371684) (Reference IEC 60601-1-2 6.8.3.201) 112
 3.2 GE Healthcare-Supplied (Optional, Long Run Length 5371684-2) (Reference IEC 60601-1-2 6.8.3.201) 113
 3.3 GE Healthcare Supplied (Cables of Options) (Reference IEC 60601-1-2 6.8.3.201).... 114
 3.4 UPS Wiring Cables (Reference IEC 60601-1-2 6.8.3.201)..... 115
 3.5 A1 UPS 115
 3.6 Contractor/Customer-Supplied 116
 3.7 Fuse..... 118
Section 4.0:Contractor Supplied Components..... 119
Section 5.0:Scan Room Warning Light and Door Interlock 120

Chapter 14

Delivery and Storage Requirements..... 121
Section 1.0:Delivery to the Facility 121
 1.1 Loading Dock Deliveries 121
 1.2 Ground (Non-Loading Dock) Deliveries..... 121
 1.2.1 Liftgate Truck 121
 1.2.2 Tiltbed Truck 121
 1.2.3 Forklift Truck 121
Section 2.0:Delivery to the Scan Suite 122
 2.1 Lifting 122
 2.1.1 Stairway Deliveries 122
 2.2 Floor Protection 122
 2.3 Un-loading and un-packing the System..... 122
Section 3.0:Dollies 123
 3.1 Installations within the United States 123
 3.2 Zero Clearance Dollies 123
 3.3 Tilting Table Dollies 123
 3.4 Installations Outside of the United States..... 123

Section 4.0:Gantry Delivery Considerations	124
4.1 Gantry Shipping State	124
4.2 Door Openings	124
4.3 Elevator Requirements.....	124
Section 5.0:Table Delivery Considerations	125
Table Delivery Considerations	125
Section 6.0:Console Delivery Considerations	126
Section 7.0:Storage Requirements	127
7.1 Short-term Storage (Less than Six Months).....	127
7.2 Construction-Site Storage	127
Section 8.0:Extreme Temperature Delivery and Storage	127
Chapter 15	
Handling Requirements	129
Section 1.0:Transportation	129
Section 2.0:Handling Requirements	129
2.1 Avoid Dropping.....	129
2.2 Avoid Shocks and Vibrations	129
2.3 Avoid Tipping	129
2.4 Inclines and Flat-bed Truck Removal.....	130

Chapter 1

Introduction

This document contains the physical and electrical data necessary for planning and preparing a site for system installation. The responsibility of arranging and paying for this work rests solely with the purchaser.

Section 1.0: What is Pre-Installation?

Pre-installation is any site preparation required prior to the installation of the system. This manual states all pre-installation siting and regulatory requirements. The Pre-Installation Kit may not answer all of your questions, contact your GE Healthcare Project Manager of Installation (PMI) for answers.

Likewise, prior to any construction or approval, General Healthcare Headquarters Architectural Planning must review all CT site plans, preliminary concepts, and final working drawings. Contact your GE Project Manager of Installation (PMI) for complete information regarding your site-specific room layout.

Section 2.0: What is Pre-Installation Work?

Pre-Installation work includes:

- Site renovation.
- Alterations or modifications to products not specifically included in the sales contract.
- Installation of electrical conduit, junction boxes, ducts, outlets, and line safety switches.
- Installation of AWG stranded copper interconnection wiring, conforming to the following requirements:
 - * The electrical contractor shall ring out and tag all wires at both ends.
 - * Wires shall be continuous and without splices.
 - * Ground wires shall conform to product requirements.
 - * Color-coded wires shall be used whenever possible, to enable easier identification.
- All work shall conform to IBC (International Building Code) and local building and safety codes.

Note: GE Healthcare neither provides nor installs the wires, conduits, junction boxes, or ducts illustrated in this publication, unless specifically mentioned.

Section 3.0: Pre-Installation Tools

A list of primary customer tools for successfully completing the pre-installation process for a Optima CT660 system appears below.

3.1 Customer Pre-Installation Task

- **Customer Pre-Installation Tasks**
- **Regulatory and Service Clearance Information**
- **Floor Template** (GT1700V: P/N 5341997, Lite Table: P/N 5193991)
 Included with system, and also available from your PMI. Use this to determine equipment layout and anchoring locations.
- **Site Print**
 Supplied by your PMI or sales rep. Must show actual room size, location of all equipment in the finished room, all service and operating clearances, and meet all regulatory requirements.

3.1.1 Pre-Installation Manual Guide

Table 1-1 shows the location in this Pre-Installation Manual of the information necessary for fulfilling each the corresponding pre-installation requirements.

Installation Site Requirement Information	
Determining Your Installation Type on page 27	System Siting Requirements on page 31
Room Dimensions on page 49	Structural and Mounting Requirements on page 71
Regulatory Requirements on page 37	Service Clearance Requirements on page 45
Radiation Protection Requirements on page 99	Network Requirements on page 103
Environmental Requirements on page 89	Power Requirements on page 105
Delivery and Storage Requirements on page 121	Handling Requirements on page 129
Contractors must complete ALL WORK before the scheduled delivery date.	

Table 1-1 Locations of Site Requirement Information in this manual

Section 4.0: Customer Pre-Installation Tasks

Required Information for Site

Must be completed before the scheduled delivery date

Hospital Name as it appears on the system screens:

Network ID numbers / IP addresses

PACS: _____

Camera: _____

AW: _____

Other - Specify type & ID: _____

Other - Specify type & ID: _____

Camera setup information: _____

AW Direct Connect address: _____

Do you want HIPAA enabled? No___ Yes ___

Do you want automatic downloads enabled? No___ Yes ___

:

GE		Cust		Dates
Y	N	Y	N	
		<input type="checkbox"/>	<input type="checkbox"/>	Has the project schedule been verified with facilities department, contractor, and GE?
		<input type="checkbox"/>	<input type="checkbox"/>	Will the committed site-ready date be met?
<input type="checkbox"/>	<input type="checkbox"/>	<input type="checkbox"/>	<input type="checkbox"/>	Does the completion date for any/all construction meet or proceed the delivery date?
<input type="checkbox"/>	<input type="checkbox"/>	<input type="checkbox"/>	<input type="checkbox"/>	Is the Power & Ground survey complete? Date: _____ Hospital contact: _____
		<input type="checkbox"/>	<input type="checkbox"/>	Is the Site-Ready visit scheduled? Date: _____
		<input type="checkbox"/>	<input type="checkbox"/>	Is the delivery date scheduled? Date: _____
		<input type="checkbox"/>	<input type="checkbox"/>	Is the installation date scheduled? Date: _____
<input type="checkbox"/>	<input type="checkbox"/>	<input type="checkbox"/>	<input type="checkbox"/>	Is the installation timing determined? A: Weekdays___ B: Weekend___ C: Quick Install___ If B or C, have all sub-contractors been notified? No___ Yes ___
<input type="checkbox"/>	<input type="checkbox"/>	<input type="checkbox"/>	<input type="checkbox"/>	Does the delivery and/or installation date need to be adjusted?
		<input type="checkbox"/>	<input type="checkbox"/>	Is the first-use date scheduled? Date: _____
<input type="checkbox"/>	<input type="checkbox"/>	<input type="checkbox"/>	<input type="checkbox"/>	Applications/Training dates scheduled? On-Site Training Date: _____ Healthcare Institute Training Date: _____

Table 1-2 Schedule Date Commitments

GE		Cust		General / Site Requirements
Y	N	Y	N	<i>Must be completed 5 weeks before scheduled delivery date</i>
<input type="checkbox"/>	<input type="checkbox"/>	<input type="checkbox"/>	<input type="checkbox"/>	Were final drawings approved and distributed to the contractors?
<input type="checkbox"/>	<input type="checkbox"/>	<input type="checkbox"/>	<input type="checkbox"/>	Are final drawings "signed off" to approve equipment layout / orientation?
<input type="checkbox"/>	<input type="checkbox"/>	<input type="checkbox"/>	<input type="checkbox"/>	Do the actual room dimensions match those on the final drawings?
		<input type="checkbox"/>	<input type="checkbox"/>	Has the radiologist health physician reviewed and approved the room layout and shielding requirements?
		<input type="checkbox"/>	<input type="checkbox"/>	Have any additional requirements or questions about the installation been discussed with GE? List: _____ _____ _____
		<input type="checkbox"/>	<input type="checkbox"/>	Is there a person assigned to review and verify that all installation requirements are met? Name: _____
		<input type="checkbox"/>	<input type="checkbox"/>	Have the specific site requirements been discussed with the contractor? Refer to the GE final drawings specifications. (See Table 1-4 below.)
		<input type="checkbox"/>	<input type="checkbox"/>	Has the responsibility of cabling, installing, and interfacing accessories not on the order been discussed?
		<input type="checkbox"/>	<input type="checkbox"/>	Are all third-party vendors identified, notified and scheduled? (Examples: Netcom, Medrad, etc.)
		<input type="checkbox"/>	<input type="checkbox"/>	Have all regulatory requirements been met per <i>Regulatory Clearances</i> , on page 37?
		<input type="checkbox"/>	<input type="checkbox"/>	Will existing network, broadband, and camera cable drops reach new locations and will they meet the requirements and function with Optima CT660? If not, what are the requirements? List: _____ _____ _____

Table 1-3 General Site Planning

GE		Cust		Equipment
Y	N	Y	N	<i>Must be completed 5 weeks before scheduled delivery date</i>
<input type="checkbox"/>	<input type="checkbox"/>	<input type="checkbox"/>	<input type="checkbox"/>	Has the order been reviewed for completeness and compatibility with existing equipment? Typical equipment: Remote monitors ____ AW relocation ____ Cardiac monitor ____ Injectors ____
<input type="checkbox"/>	<input type="checkbox"/>			Are interfaces to existing and/or new accessories ordered and planned for accordingly?
<input type="checkbox"/>	<input type="checkbox"/>	<input type="checkbox"/>	<input type="checkbox"/>	Have the following peripheral locations been included in the site drawings? Cardiac monitor ____ Injector control ____ Laser camera ____ UPS ____ 2 nd Monitor ____
<input type="checkbox"/>	<input type="checkbox"/>	<input type="checkbox"/>	<input type="checkbox"/>	Will GE Healthcare provide additional services per contract negotiations?
<input type="checkbox"/>	<input type="checkbox"/>			Are correct length cables on order?

Table 1-4 Equipment Compatibility

GE		Cust	Network Installation and Setup
Y	N	Y	N
<i>Must be completed 5 weeks before scheduled delivery date</i>			
<input type="checkbox"/>	<input type="checkbox"/>	<input type="checkbox"/>	<input type="checkbox"/>
			Have IP addresses and Host Names been obtained? No___ Yes ___
<input type="checkbox"/>	<input type="checkbox"/>	<input type="checkbox"/>	<input type="checkbox"/>
			Will a network camera be used? No___ Yes ___
<input type="checkbox"/>	<input type="checkbox"/>	<input type="checkbox"/>	<input type="checkbox"/>
			Required: Is the network installed, are network jacks installed, and is the entire network tested?
<input type="checkbox"/>	<input type="checkbox"/>	<input type="checkbox"/>	<input type="checkbox"/>
			Required: Broadband VPN installed/setup?
<input type="checkbox"/>	<input type="checkbox"/>	<input type="checkbox"/>	<input type="checkbox"/>
			Required: Are network software options ordered ____ HIS RIS option ____ DICOM print ___ AW ____
<input type="checkbox"/>	<input type="checkbox"/>	<input type="checkbox"/>	<input type="checkbox"/>
			Optional: Has modem option ordered? _____ (Requires a site escalation)
<input type="checkbox"/>	<input type="checkbox"/>	<input type="checkbox"/>	<input type="checkbox"/>
			Optional: Is the Optima CT660 service telephone line identified and installed for InSite? (Electrical, mechanical, etc.)

Table 1-5 Network Connections

GE		Cust	Other
Y	N	Y	N
<i>Must be completed 5 weeks before scheduled delivery date</i>			
<input type="checkbox"/>	<input type="checkbox"/>	<input type="checkbox"/>	<input type="checkbox"/>
			Arrangements made in the schedule to allow adequate time for remodeling, if required (such as wall, floor, or ceiling repair work, painting, other cosmetic finishes)
<input type="checkbox"/>	<input type="checkbox"/>	<input type="checkbox"/>	<input type="checkbox"/>
			Have arrangements been made to clean the floor <i>after</i> equipment removal and <i>prior</i> to the installation of the new equipment?
<input type="checkbox"/>	<input type="checkbox"/>	<input type="checkbox"/>	<input type="checkbox"/>
			Is de-installation of existing equipment required? No___ Yes ___ Removal date _____
<input type="checkbox"/>	<input type="checkbox"/>	<input type="checkbox"/>	<input type="checkbox"/>
			Is there a trade-in of existing equipment? No ___ Yes __ GoldSeal _____
<input type="checkbox"/>	<input type="checkbox"/>	<input type="checkbox"/>	<input type="checkbox"/>
			Delivery route identified and verified with the proper hospital personnel? No___ Yes ___ Elevators and doors checked for size and weight constraints? No___ Yes ___
<input type="checkbox"/>	<input type="checkbox"/>	<input type="checkbox"/>	<input type="checkbox"/>
			Have appropriate arrangements been made with traffic for delivery? No___ Yes ___
<input type="checkbox"/>	<input type="checkbox"/>	<input type="checkbox"/>	<input type="checkbox"/>
			Will acceptance/performance testing or bio-medical testing be required? No___ Yes ___ Date: _____
<input type="checkbox"/>	<input type="checkbox"/>	<input type="checkbox"/>	<input type="checkbox"/>
			Are trash and/or recycling bins available for the removal of papers, boxes, etc. during the installation? No___ Yes ___
<input type="checkbox"/>	<input type="checkbox"/>	<input type="checkbox"/>	<input type="checkbox"/>
			Has the GEHC Surface Penetration Permit been completed before equipment delivery? (A copy of this form must be sent to GEHC as defined in the permit.) No___ Yes ___

Table 1-6 Miscellaneous Tasks

This Page Intentionally Blank.

Chapter 2

Installation Types

Section 1.0: Determining Your Installation Type

1.1 How to Determine the Best Installation Type for Your Site

Discuss installation options with your PMI to determine which of the installation types listed below best fits your site and schedule.

1.2 Typical Installations

Typical installations occur at established sites with finished, dust-free, occupancy-ready scan suites. The rooms range from suggested to minimum room sizes, and have NO ongoing construction on-site. A typical installation allows customers flexibility for room upgrades and site improvements. Upgrades and improvements may require additional planning prior to system delivery, especially when involving:

- Seismic approval
- Floor structural improvements
- HVAC improvements
- Electrical Improvements
- Review of scan room shielding requirements by a qualified radiological health physicist.

As with any installation, the final site design for a typical installation must meet all service and regulatory requirements detailed in this manual.

1.3 Construction Site Installations

A construction installation describes installations at sites without an occupancy permit, often with ongoing construction. In general, construction sites fail to meet the recommended specifications for delivery of the system. GE Healthcare does not recommend construction installations, as they can result in delays, increased costs, and possible damage to the system. When construction-site delivery proves unavoidable, the installation falls into one of two categories:

- Full construction site with completed radiology area
- Full construction site with limited delivery access

Review the following categories to determine which most closely matches the condition of the planned installation site.

1.3.1 Full Construction Site with Completed Radiology Area

This type of site consists of a finished, dust-free, occupancy-ready radiology suite. While there is no remaining construction in or around the scan suite area, there may be ongoing construction in other areas. At the time of delivery such sites feature:

- Dust control measures deployed in the radiology suite area.
- Scan suite access limited to a single entrance (see [Figure 2-1](#)).
- Radiology suite sealed off from the remaining construction area.
- Operational HVAC, with a positive air pressure within the radiology suite.

In addition, the radiology suite at such a site REMAINS in a dust-free, occupancy-ready state after delivery and throughout the remaining construction phase.

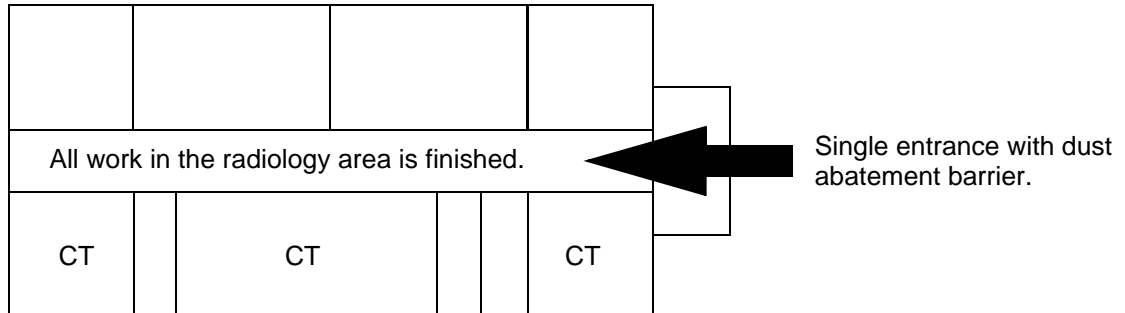

Figure 2-1 Full construction site with completed radiology area

1.3.2 Full Construction Site with Limited Delivery Access

This type of site allows delivery during ongoing construction of the radiology suite area. At such sites, delivery occurs prior to site completion, but the product remains stored until a finished, dust-free, occupancy-ready radiology suite area is ready. This type of site requires the Optima CT660 Series to be delivered in a sealed package with dollies. Delivery to the storage area may require a lift truck or riggers. Installation work begins only when the site reaches the completed, dust-free, occupancy-ready radiology suite requirement.

Note: If delivery requires vertical or horizontal lifting, the PMI adds the necessary identifier to the order.

1.4 Relocatable Building Installations

A relocatable building is made in a factory and delivered to the site of its permanent location. Relocatable buildings qualify as fixed sites and must satisfy all of the requirements of a fixed site. The gantry and table must be mounted on a solid concrete floor. Any other floor type installations must be designed by the customer's structural engineer and meet all GE Healthcare's specifications listed in this manual.

Refer to [Structural and Mounting Requirements on page 71](#) of this manual for further information.

1.5 Upgrade Installations

Upgrade installations occur after the installation of another system. A change in the customer's needs requires the installation of additional equipment at the same site. For example, adding a PET system to an existing CT system.

To proceed with an upgrade installation, the customer's room size must be large enough to accommodate the new product without violating the regulatory and service requirements of the new product. When planning for an upgrade installation, siting requirements of the new equipment may exceed those of your existing system. Requirements needing additional consideration include:

- Floor thickness
- Room shielding
- Additional electrical capacity
- Increased cooling capacity
- Scan room shielding requirements

The final site design must include a room layout showing the equipment room with the recommended room size dimensions. All upgrade installations must meet all service and regulatory requirements detailed in this manual.

1.6 Quick Installations

Quick Installations involve sites requiring minimum room improvements. These installations typically consist of a weekend de-installation and room prep completion, with a next-business-day delivery and installation.

1.6.1 Requirements

A site must meet a number of requirements to qualify for a Quick Installation, including:

- Existing electrical disconnect device, wire size, and grounds must meet all requirements referenced in [Chapter 3, Section 2.2 on Page 34](#).
- Existing structural specifications met, including floor thickness, and all requirements referenced in [Chapter 3, Section 2.3 on Page 35](#).
- Existing HVAC capacity and regulation must meet all requirements referenced in [Chapter 3, Section 2.5 on Page 35](#).
- Existing CT suite must meet all regulatory and minimum size requirements referenced in [Chapter 3, Section 2.7 on Page 36](#).
- Existing facility must accommodate delivery and meet all delivery requirements referenced in [Chapter 3, Section 2.9 on Page 36](#).
- Existing facility must meet all scan room shielding requirements referenced in [Chapter 10](#).

Consult your Project Manager of Installation (PMI) for information about any additional requirements.

1.6.2 Restrictions

The following restrictions govern Quick Installations:

- Quick Installs require a new room print that accurately reflects the rooms targeted for upgrade.
- You CANNOT re-use existing floor anchors from a non-Optima system.
- New floor anchors must be a minimum of 102 mm (4 in.) from any existing floor penetrations.
- Rooms not meeting the minimum requirements for the final product must undergo an upgrade/enlargement prior to installation.

1.7 Two-Step (Temporary) Installations

Two-Step installations are the temporary installation of one system in a site, with the intention of upgrading the site to another system at a later date. The following restrictions apply to two-step installations:

- Must comply with ALL siting requirements necessary for the upgraded or final system. This includes the recommended room size and all electrical, structural, and HVAC requirements.
- All requirements referenced in [Chapter 3, Section 1.0](#) and [Chapter 3, Section 2.0](#) apply to these installations.
- The customer is responsible for verifying compliance with all requirements.
- Rooms not meeting minimum requirements for the final product must undergo sufficient upgrading/enlargement.

Note: Temporary installations include all systems installed at a site for a period ranging from two weeks to six months.

Chapter 3

System Siting Requirements

Section 1.0: System Siting Requirements

The requirements listed in this manual apply to all fixed-site customer installations, including installations within relocatable buildings. The following requirements represent the MINIMUM that a site must meet before beginning ANY new or replacement system installation. All parties should review these requirements to ensure that the site:

- Meets all service requirements.
- Meets all regulatory requirements.
- Meets all minimum structural, flooring, and vibration requirements.
- Meets minimum HVAC requirements.
- Meets minimum electrical requirements.
- Meets all network requirements.
- Meets radiation protection requirements.
- Meets all operational clearances.
- Includes all finished doors, floors, windows, ceilings, and walls, with all plumbing and cabinets already installed. (**Finished Floor Exception 1 on page 75** and **Finished Floor Exception 2 on page 75** may apply. Finished Walls Requirements on page 76 may apply.)
- Does not have ANY continuing construction in the scan room OR neighboring suite areas.
- Conforms to the final GE Healthcare site print, which must be kept ON-SITE and must show all items intended for the finished room.

Note: Each site receives a Quick Start Kit from its PMI. Use the Pre-Install Checklist in the Pre-Installation Manual to confirm that the site meets all of the requirements listed above. GE Healthcare recommends completing all work to meet these requirements PRIOR to starting installation.

Section 2.0: Customer System Siting Requirements

This section provides a breakdown of customer tasks crucial for ensuring proper site preparation, regardless of whether planning for a replacement system at an existing site, or designing a new scan room for a first system.

Installation cannot proceed until verification of site-readiness occurs. A site is ready **ONLY** when it meets ALL delivery, regulatory, system, network, radiation protection, and operational requirements, as well as requirements for any options. The purchaser is responsible for completing all work necessary to install the system, and includes:

- Completion of all items in [Section 2.3, Structural](#) (recommended before installation begins).
- PMI verification that ALL items on the Pre-Installation Checklist are completed.
- Review and preparation of all site-ready items.

To ensure timely delivery and installation, GE Healthcare recommends that the customer complete all necessary work and schedule a site-ready visit prior to the delivery date.

To confirm that the site meets all requirements, you may need to employ these and other contractors:

- Structural Engineer and/or Architect
- HVAC Contractor
- Electrical Contractor
- Qualified Radiological Health Physicist
- Cleaning Services

 **NOTICE** **SERVICE NOTICE: An improperly prepared site, one that is in a state of construction, can result in a delayed installation date and/or damage to the system.**

2.1 Regulatory Requirements

Verify that the site conforms to all of the following:

- The room meets all regulatory clearance requirements.
- The room meets all minimum size requirements.
- The site print is on-site, reflects actual room size and layout, and has received final approval.
- The room meets all local codes.

2.2 Electrical

- Install the correct size junction boxes with covers at locations shown in the installation plan.
- Install appropriate conduits and duct work for system cables. If the suite houses additional components, determine the necessary considerations and complete the connections.
- Install a power supply of correct voltage output and adequate kVA rating.
- Install local disconnects, including proper over-current protection. This includes the A1 main disconnect with Lock-out and Tag-out (LOTO) installation.

2.3 Structural

- Install "steelwork" or other suitable support work for mounting equipment from walls or ceilings.
- Review structural requirements, including:
 - Floor vibration
 - Floor levelness
 - Floor thickness,
 - Any seismic considerations, if applicable.
- Complete all suite and room renovations and modifications prior to delivery.

2.3.1 Air / Dust Quality

Ensure that the scan suite area is free of all dust, and not subject to ANY ongoing construction, including the installation of cabinets, hanging doors, and ceiling tiles.



NOTICE

SERVICE NOTICE: Because the system's air-intake is near the bottom of the gantry (as shown in [Figure 7-2](#)) and draws in air through a filter in the gantry heater assembly, fine dust -like that created during room construction or renovation -can clog this and other filters found on the DAS, tube, and console. If this occurs, dust may become deposited throughout the gantry, table, console, and PDU electronics. Once inside the unit, removal becomes impossible, resulting in potential DAMAGE to electronic components and EARLY SYSTEM FAILURE. Consequently, the system is the LAST item installed in the scan suite area.

TYPES OF DUST TO AVOID

Ensure that NO construction occurs in or immediately around the scan suite area that results in:

- Concrete dust
- Drywall dust
- Ceiling tile dust
- Wood sawdust or shavings
- Dust tracked into the CT suite from adjoining rooms

Failure to take appropriate precautions to protect the system against these types of dust may result in DAMAGE to the system and early SYSTEM FAILURE.

2.3.2 Environmental Influences

CT systems are designed with commercial components that are sensitive to air contaminants like sulfide, chloride and nitrates. It is the responsibility of the purchaser to ensure that the levels of these contaminants are low (Class 1). See IEC60654-4 for air quality guidelines.

2.3.3 Finished Floor Requirements

Installation requires a finished floor in the scan and control rooms. The scan room must be level by 6 mm (1/4 in) over the table and gantry area to be acceptable. You cannot use shims to level the floor. Eight or more floor covering openings that are 102 mm (4 in) in diameter are made to ensure the table and gantry rest on a solid surface. These floor penetrations can be sealed if required. These requirements apply to all installation types.

FINISHED FLOOR EXCEPTION 1

For sites replacing their scan room floor covering after the table and gantry are installed, the floor can be clean-finished with dust-free concrete. The finish floor in the scan room requires no dust-producing operations when applying final floor covering.

FINISHED FLOOR EXCEPTION 2

Facilities under new construction that have a finished radiology area with a single controlled-access and dust abatement barrier, can have a finished concrete floor in the scan room. The finished concrete floor in the scan room requires no dust-producing operations when applying final floor covering.

2.3.4 Finished Walls

Finished walls inside the scan and control rooms must be painted at the time of installation. This requirement applies to all installation types.

A finished walls exception is made for the following condition:

In new construction and upgraded facilities, a primer coat of paint is acceptable for equipment installation. However, the final coat of paint must be applied using a brush of some type (e.g. roller or bristle). The final coat of paint cannot be applied using a spray method.

2.4 Radiation Protection

A qualified radiological health physicist should verify that the scan room's radiation shielding provides adequate radiation protection for the planned system.

2.5 Environmental

Review HVAC requirements, including system environmental controls and patient comfort needs. Make sure the site provides an HVAC system capable of maintaining the recommended temperature and humidity specifications at the time of installation.

2.6 Options

Confirm the following:

- All customer installation options reviewed and final locations determined.
- All GE-supplied installation options reviewed and final locations determined.
- The laser camera should be on-site at the time of system installation.

2.7 Clearances

- Review operational clearances to verify whether daily use items fit (e.g. beds and carts).
- Consider clearances for emergency medical equipment.
- Ensure that all storage cabinets and sinks appear on the site print in their proper locations.
- Confirm that adequate space exists in the scan suite for delivery and installation of all replacement parts following installation of the system.

2.8 Network

Ensure that network communication is in place and active.

2.9 Chemical Contamination

Never install wet film processors in the same room as the system, as this may result in possible contamination of the system components. Chemicals utilized by such processors can contribute to increased equipment failures and downtime, and decreased reliability.

When siting this equipment, consider the effects that contact with these chemicals and the resulting fumes might have on human subjects in proximity to them. In addition, film processor equipment installation must meet all manufacturer requirements (e.g. ventilation specifications) as well as all applicable local, state, and national codes.

2.10 Delivery

- Determine room dimensions and verify that doorways adequately accommodate the system.
- Verify the existence of an accessible, dust-free, non-construction-zone route to the scan suite that accommodates delivery.
- Identify elevators, doorways, and hallways that can accommodate delivery.
- Provide floor protection, if needed.
- Request rigging, if needed.

Section 3.0: Site Readiness

3.1 Pre-Installation Tasks

The GE Healthcare Project Manager of Installation (PMI) assists the purchaser in meeting all system siting requirements.

3.1.1 Pre-Installation Delivery Tasks

The PMI also performs the following pre-installation delivery tasks:

- Determines the delivery type: ground, dock, or tilt-bed truck.
- Determines if delivery requires tilt dollies or riggers; orders dollies and lifting crates, as needed.
- Determines if the delivery requires the use of floor protection.
- Determines if ground delivery requires the use of a tilt-bed truck, and informs GE Transportation of the need for a tilt-bed truck.

3.1.2 Site Review with Customer

A site-ready visit should occur prior to the delivery date. This visit verifies that the site meets all system siting requirements and confirms that installation can proceed. During the site-ready visit, a GE representative confirms that the site meets all of the required site-ready conditions including floor levelness, and delivery route readiness. Lifting options and construction site packaging must be ordered prior to delivery and cannot be added on-site.

Chapter 4

Regulatory Requirements

Section 1.0: Regulatory Clearances

1.1 Regulations

Review all codes in your area prior to your installation date. US customers should consider these codes:

- 29 CFR 1910 (OSHA)
- NFPA 70E (STANDARD FOR ELECTRICAL SAFETY IN THE WORKPLACE)
- NFPA 101 (LIFE SAFETY CODE)
- AMERICANS WITH DISABILITIES ACT



NOTICE

All systems installed within the United States and United States territories, and within U.S. government facilities, regardless of country, must comply with all United States Federal and local regulations. All systems installed outside the United States must comply with either the national, state, or local regulatory clearance requirements for the country in which the installation occurs, or U.S. Federal regulations, whichever is greater.

1.2 Clearance Requirements

A map of clearance requirements necessary for U.S. regulatory compliance is provided in [Figure 4-1, on page 38](#).

Note: A similar map of detailed dimensional clearance measurements necessary for safe servicing of the system is provided in [Figure 5-1, on page 47](#).



NOTICE

The maps and dimensions shown in this manual depict the required clearances for proper equipment operation and service only. The customer/purchaser is responsible for federal, state and/or local codes regarding facility egress and related facility requirements.



NOTICE

The use of alternative layouts from the appendix puts severe limitations on space for patient care and work flow. Customer approval of site drawings signifies customer agreement to these limitations.

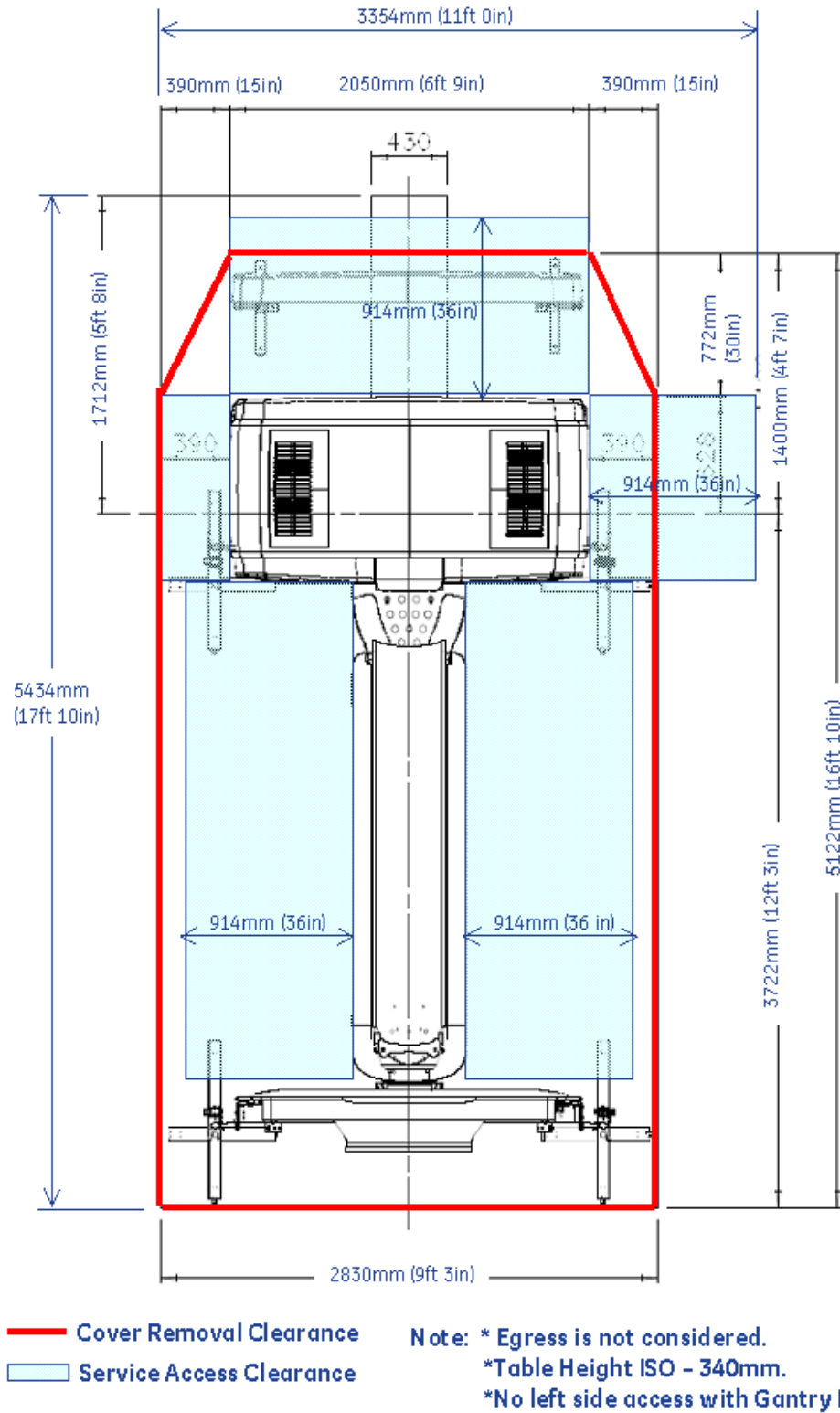

Figure 4-1 Regulatory Clearance Requirements for the Optima CT660 with GT1700V Table

1.2.1 Minimum Regulatory Workspace Clearances by Major Subsystem

Note the following when referring to the tables below:

- These requirements apply to equipment operating at 600 V or less, where examination, adjustment, servicing, or maintenance is likely to be performed with live parts exposed.
- The customer MUST maintain the required regulatory clearance distances and may NOT use these areas for storage. This applies during normal system operation as well as during service inspection and maintenance.
- Direction of Service Access refers to a direction perpendicular to the surface of the equipment serviced.

Workspace Requirement	MINIMUM CLEAR SPACE	ADDITIONAL CONDITIONS
Direction of Service Access (Front and Rear of Console)	N/A (No exposed live part hazards.)	
Service Access Width (Front-Back of Workspace)		Refers to the width of the working space in front of equipment. 762 mm (30 in.) min or the equipment width, whichever is greater.
Head Clearance	1981 mm (78 in.)	Refers to the height of the workspace measured from the floor at the front edge of the equipment to the ceiling or any overhead obstructions. 1981 mm (78 in.) or the height of the equipment, whichever is greater.

Note: Distances are measured to the finished covers.

Table 4-1 Console . Minimum workspace Clearances

Workspace Requirement	Minimum Clear Space	Additional Conditions
Direction of Service Access (Front of PDU)	914 mm (36 in.)	1219 mm (48 in.) if exposed live parts of 151 - 600 volts are present on both sides of operator between. 1067 mm (42 in.) if the opposite wall is grounded and exposed live parts of 151 - 600 volts are present.
Service Access Width (Front of Workspace)	762 mm (30 in.)	Refers to the width of the working space in front of equipment. 762 mm (30 in.) min or the equipment width, whichever is greater.
Head Clearance	1981 mm (78 in.)	Refers to the height of the workspace measured from the floor at the front edge of the equipment to the ceiling or any overhead obstructions. 1981 mm (78 in.) or the height of the equipment, whichever is greater.

Table 4-2 Minimum Workspace Clearances

Note: For the Gantry and Table, distances are measured from the finished covers

Workspace Requirement	Minimum Clear Space	Additional Conditions
Direction of Service Access (All Sides)	914 mm (36 in.)	1219 mm (48 in.), if exposed live parts of 151 - 600 volts are present on both sides of the workspace with the operator between. 1067 mm (42 in.), if the opposite wall is grounded and exposed live parts of 151 - 600 volts are present.
Service Access Width (Left-Right of Workspace)	762 mm (30 in.)	Refers to the width of the working space in front of equipment. 762 mm (30 in.) minimum or the equipment width, whichever is greater.
Head Clearance	1981 mm (78 in.)	Refers to the height of the workspace measured from the floor at the front edge of the equipment to the ceiling or any overhead obstructions. 1981 mm (78 in.) or the height of the equipment, whichever is greater.

Table 4-3 Gantry . Minimum Workspace Clearances

Workspace Requirement	Minimum Clear Space	Additional Conditions
Direction of Service Access (Table Head)	N/A	
Direction of Service Access (Table Sides)	914 mm (36 in.)	*Can reduce to 711 mm (28 in.), provided the local team obtains written and signed approval from the local AHJ (Authority Having Jurisdiction). GE must have the signed document on file.
Direction of Service Access (Table Foot)	711 mm (28 in.)	457 mm (18 in.) minimum for Front Gantry Cover removal, only if an unobstructed egress space of 711 mm (28 in.) exists around the equipment for room exit, and no trip hazards exist along the path of egress.
Service Access Width (Left-Right of Workspace)	762 mm (30 in.)	Refers to the width of working space in front of equipment. 762 mm (30 in.) minimum or the equipment width, whichever is greater.
Head Clearance	1981 mm (78 in.)	Refers to the height of the workspace measured from the floor at the front edge of the equipment to the ceiling or any overhead obstructions. 1981 mm (78 in.) or the height of the equipment, whichever is greater.

Table 4-4 Table . Minimum Workspace Clearances

1.3 How to Measure

Figure 4-2 offers guidance on the proper way to measure to check minimum regulatory clearances.

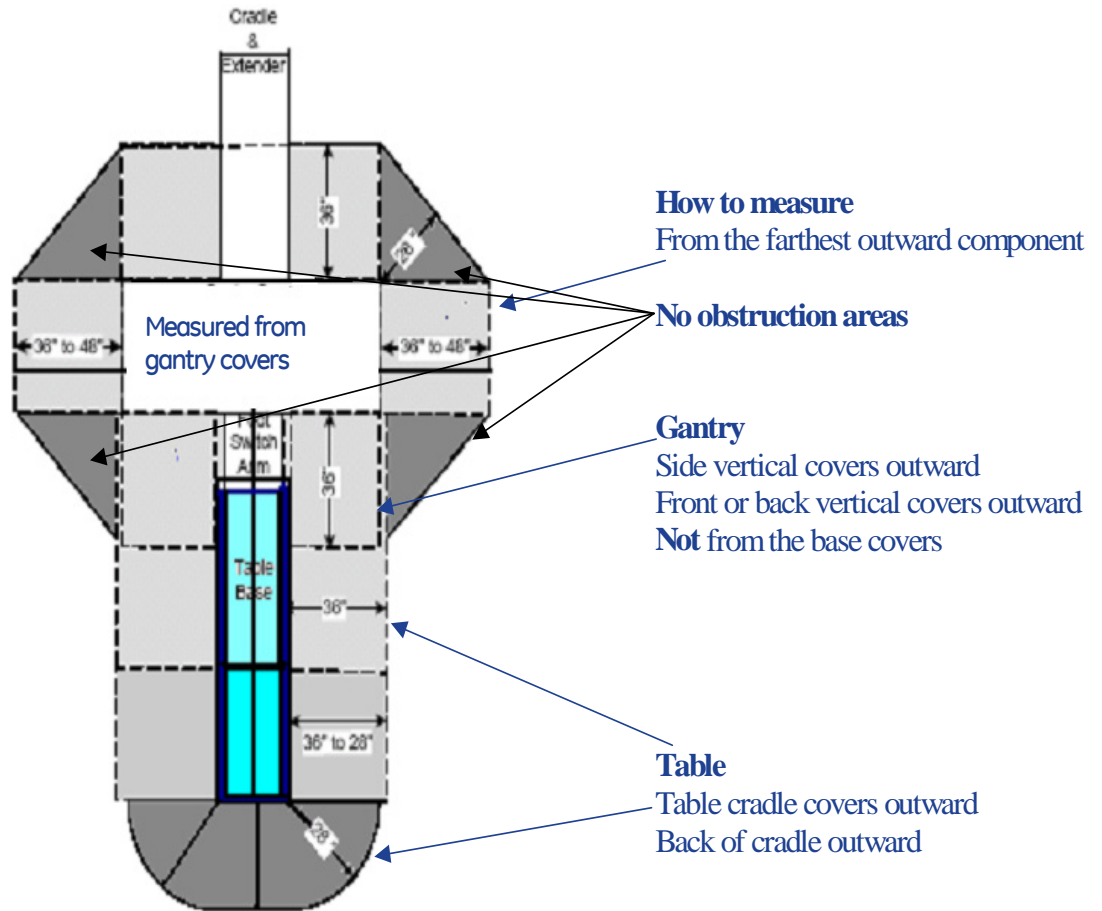

Figure 4-2 Measuring Minimum Regulatory Clearances



CAUTION

Regulatory Caution: All system installations, relocations, and moves, require site prints. The CT room layout shall match the layout shown on your site print and meet all regulatory requirements described in the installation manual. Additional room components, such as cabinets and sinks, reduce room size. Consequently, equipment not shown on the site print may void the caution statement, making the room NON-COMPLIANT. Actual site measurements obtained by the mechanical installer before installation determines room size and compliance.



CAUTION

Operational Caution: In the minimum room layout (356 mm to 686 mm [14 in. to 27 in.]) the customer should consider workflow, customer access for patient care, and critical-care operations space requirements. Additionally, this layout may offer only limited equipment access on the gantry left side when loading patients or when positioning patient equipment in the room between the gantry and the wall.

1.4 NEC Conduit and Duct Fill Rate

Full operation, service, and safety of the system requires the maintenance of sufficient regulatory and service clearances around equipment.

Cable length is an important consideration in room layout. The Optima CT660 system ships with standard (short) length cables, with a set of longer cables available as an option. Refer to the electrical page of your GE site print for the specific requirements of your site. The following rules govern cable usage for the system:

- When possible, use the rear cable cover assembly to let cables enter the gantry from the rear.
- Do not cut or otherwise shorten long cables.
- Do not store excess cable length behind the Console, gantry, or PDU.
- Store excess cable in wall or floor ducts, if desired, provided that sufficient space exists. Refer to NEC code to determine cable fill rates for conduits and ducts.
- All installed systems shall comply with NFPA 70-E Electrical Regulations governing conduit or duct fill.

Section 2.0: Terms and Definitions

CLEARANCES

Clearances are the clear space or distance between or around objects and equipment, governed by all applicable safety, service, and regulatory requirements and representing the lowest margin of freedom permissible for equipment siting.

DIMENSIONS

Dimensions are the length, width, depth, and height of equipment.

EGRESS

An egress is the single path of exit from within any room. It is the customer's responsibility to provide a means of egress.

(PRE-INSTALLATION) ESCALATION

Pre-installation escalation is the process used to consult CT Engineering, the Design Center, or EHS to resolve pre-installation issues related to siting concerns and requirements.

GROUNDING WALL

A grounded wall is any wall with electrical conductivity to earth. Conductive materials generally found in walls include masonry, concrete, and tile. Treat as grounded additional elements commonly found in walls, including but not limited to:

- Medical gas ports and plates
- Metal doors and window frames
- Water sources and metallic sink structures
- Metallic wall-mounted cabinets
- A1 main disconnect panel
- Equipment Emergency Off panels
- Industrial equipment (such as air conditioners and vents)
- Expansion joints
- Surface raceway
- Exposed wall conduits
- Floor outlet boxes
- Floor HVAC boxes
- Floor medical gas

Common wall components NOT constituting grounded elements include:

- Standard wall outlet
- Light switches
- Telephones
- Communication wall jacks
- Ceiling tile grids

HEAD CLEARANCE

Head clearance represents the height dimension of the workspace, measured from the floor at the front edge of the equipment to the ceiling or any overhead obstructions. It requires a minimum of 1981 mm (78 in.), or the height of equipment, whichever is greater.

MINIMUM

Minimum indicates the lowest limit permitted by law or other authority.

SERVICE ACCESS WIDTH

Service access width refers to the width of the working space in front of the equipment, and requires a minimum of 762 mm (30 in.) or the width of the equipment, whichever is greater.

WORKSPACE

The *workspace* represents a three-dimensional box of space required for safe inspection or service of energized equipment. It consists of depth, width, and height, with the depth dimension measured perpendicular to the direction of access. U.S. regulation requires a minimum depth of 914 mm (36 in.). Additional conditions can increase the minimum requirement. For example, FCT defines *workspace* as the envelope of the component superstructure, measured for the PDU with the front panel removed, and measured for the gantry and table with the external covers removed.

Chapter 5

Service Clearance Requirements

Section 1.0: Service Clearance Requirements

- Sufficient space to remove the covers [Figure 5-1](#).
- One service engineer shall be able to accomplish all service component replacement tasks without needing special tools or equipment.
- ALL room layouts to provide service space and access around the table to the gantry right side. This is needed for replacement procedures that require components that ship in large boxes, such as the tube, detector, and HV tank.

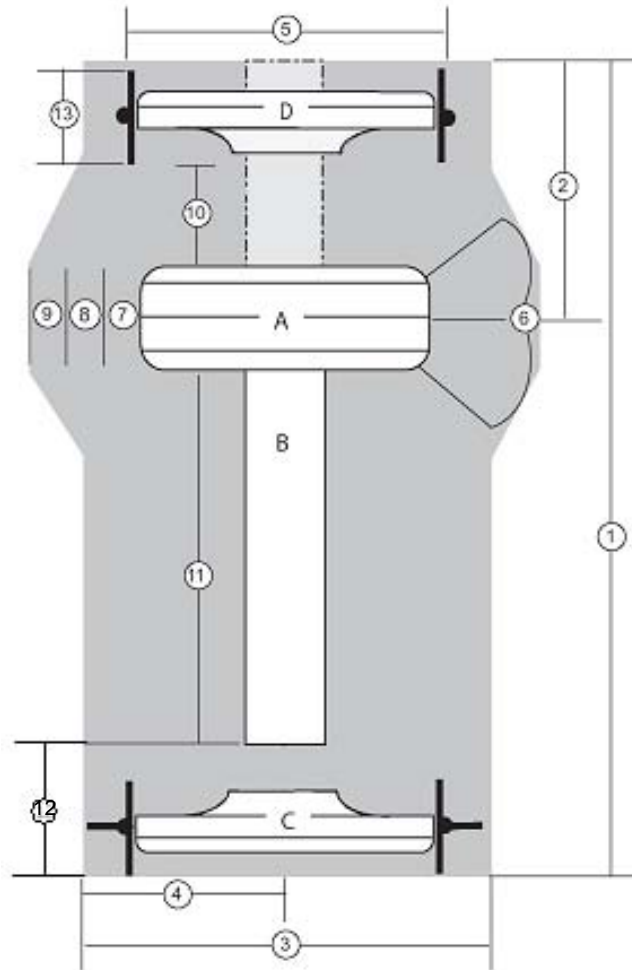

Figure 5-1 Minimum Service Clearances

Minimum Clearances

Item	Dimension
1	GT1700V Lite Table 5434 mm (18 ft.) 5179 mm (17 ft.) (travel distance of table)
2	GT1700V Lite Table 1712 mm (68 in.) 1537 mm (61 in.) (cover with dolly)
3	2830 mm (112 in.)
4	1415 mm (56 in.)
5	2006 mm (79 in.)
6	914 mm (36 in.) minimum
7	390 mm (15 in.)
8	711 mm (28 in.)
9	914 mm (36 in.)
10	914 mm (36 in.)
11	GT1700V Lite Table 2744 mm (108 in.) 2610 mm (103 in.)
12	678 mm (27 in.)
13	500 mm (20 in.)

CT Components

Item	Description
A	Gantry with covers installed
B	Table cradle footprint, coverage as extended in both directions
C	Front gantry cover removed with dolly
D	Back gantry cover removed with dolly

Section 2.0: Service Clearances for Single Service Engineer

Note: When calculating service clearances, refer to [Figure 5-1](#) for all service clearance needs.

2.1 Cover Removal

- Gantry front cover removal requires the use of the Tilting Cover Dollies and a minimum clearance space of 2830 mm (112 in.) to maneuver the cover, as illustrated in [Figure 5-1](#). The dollies allow the service engineer to separate the cover from the gantry, tilt it 90 degrees, roll it to the foot end of the table, and then tilt it an additional 90 degrees, so that it is upside-down relative to its normal system-mounted condition. After removal, the service engineer must then move the gantry front cover to a position that satisfies the minimum regulatory clearances.
- The gantry rear cover, with service dollies installed, requires a clearance width of 2006 mm (79 in.) and a depth of 914 mm (36 in.) for removal, as shown in [Figure 6-2](#). Sufficient space to allow the service engineer to move the cover either straight back or to one side of the table to satisfy the minimum service clearances shown in [Figure 5-1](#) must be maintained. The rear cover with dollies cannot extend past the allowable clearance space within the room (see [Figure 5-1](#)). If the system is not sited straight (it is positioned diagonally), full service space is still required. The PMI and customer should discuss this consideration and make the necessary provisions.
- The scan room must offer sufficient space to allow adequate egress during service operations that require both front and rear cover removal. If the customer and PMI have any concern that site will not provide adequate space for egress under these conditions, they should discuss these requirements and make the necessary provisions to accommodate this event.
- A single service engineer can safely perform servicing of the table. Ensure sufficient clear space to maintain egress clearances with the table covers or cradle removed.
- A single service engineer can safely perform servicing of the system. Ensure sufficient clear space to maintain egress clearances with covers or cradle removed.
- A tube change box is 700 mm x 1813 mm (28 in. x 6 ft.), with the handles extended. The box rolls like a wheelbarrow and must have access to the right side of the gantry. It is the PMI's responsibility to demonstrate that the tube change box can be positioned in the tube change area next to the gantry and that the front and rear covers can be removed.

2.2 Power Distribution Unit (PDU)

When positioning the Power Distribution Unit (PDU), consider regulatory compliance, as defined in [Chapter 4, Section 1.0](#), Regulatory Clearances. See [Table 4-2](#) in that section.

2.3 Console

The console does not present an exposed live parts hazard. However, the site shall maintain a working space at all times with a minimum depth of 1219 mm (48 in.), extending the full width of the console for service activity.

The console is on wheels. As some service activities require access to the rear of the console, be sure to maintain sufficient space for moving the console to allow rear service access.

See [Figure 6-5](#) for a typical control room layout.

2.4 Storage Cabinet

GE Healthcare provides a storage cabinet (see Note below) for storing all supplied service equipment (see Table 5-1). Situate this storage cabinet within the scan room suite area to allow easy service access. The dimensions of the cabinet measure 457 mm D x 914 mm W x 1067 mm H; ~ 41 kg (18 in. D x 36 in. W x 42 in. H; ~90 lbs).

Note: A storage cabinet is provided as option (B77292CA).

Item	Size	Weight (total)	
QA Phantom (water filled)	20 cm x 15 cm (7.9 in. x 5.9 in.)	5.5 kg	12 lb
35CM Phantom	35 cm x 7 cm (13.8 in. x 2.8 in.)	8.2 kg	18 lb
Phantom Holder	25 cm x 25 cm (9.8 in. x 9.8 in.)	3.6 kg	8 lb
FE Box (Purple)	30 cm x 38 cm x 30 cm (11.8 in. x 15 in. x 11.8 in.)	6.8 kg	15 lb
Install Support Kit (box)	30 cm x 30 cm x 38 cm	9.1 kg	20 lb
Three Piece Tube Hoist Assembly	77 cm x 8 cm and 38 cm x 15 cm (30.3 in. x 3.1 in. and 15 in. x 5.9 in.)	9.1 kg	20 lb
Balance Weight Kit		33 kg	73 lb
Front Cover Dollies	85 cm x 20 cm and 85 cm x 15 cm (33.5 in. x 7.9 in. and 33.5 in. x 5.9 in.)	15.9 kg	35 lb

Table 5-1 Equipment Stored in Storage Cabinet

Chapter 6

Room Sizes

Section 1.0: Room Dimensions

System Configuration	Suggested / Typical Room Size *1	Minimum Room Size *2
Optima CT660 with GT 1700V Table	6283 mm x 4003 mm (20 ft, 8 in. x 13 ft, 2 in)	5675 mm x 3901 mm (18 ft, 8 in x 12 ft, 10 in)
Optima CT660 with Lite Table	6283 mm x 4003 mm (20 ft, 8 in. x 13 ft, 2 in)	5675 mm x 3901 mm (18 ft, 8 in x 12 ft, 10 in)

¹All service/regulatory requirements apply.

²All service/regulatory requirements apply, with the addition of no energized left-side service.

Table 6-1 Scan Room Size Dimensions

1.1 Suggested Room Size

The suggested room configuration offers the most flexibility for future upgrades. It provides both ample workspace and space to add millwork and still meet all regulatory requirements. When local regulations require a sink in the scan room, this room size also provides sufficient space for a sink. This room size accommodates the needs of larger hospitals and medical teaching facilities, where patients may require transportation to the scan area in beds, gurneys, and larger wheelchairs and where they may require the assistance of larger medical care teams. Likewise, this room offers adequate access for crash carts and other emergency medical equipment on both sides of the table. Future upgrades may need additional equipment. You may want to consider an equipment room. The suggested size supports all service activities, including tube change, and accommodates all future two-step installations.

1.2 Typical Room Size

The typical room configuration represents what is most commonly found at installation sites. It offers adequate workspace and may provide adequate space for a sink, but allows only LIMITED space to add millwork and still meet all regulatory requirements. The size of this room accommodates the needs of larger clinics and medium-sized hospitals, where patients may require transportation into the scan area using gurneys and wheelchairs, and where they may require the assistance of small medical care teams. It provides access for crash carts and other emergency medical equipment on only one side of the table.

The typical room size supports all service activities, including tube change, and may offer compatibility with SOME future upgrades and two-step installations.

1.3 Minimum Room Size

The minimum room configuration represents the smallest functionally acceptable space for this product and represents the type of room often found at doctor’s offices and smaller clinics and outpatient facilities. Due to its limited size, and to functional and regulatory requirements, this room

usually provides only LIMITED workspace, and leaves to NO space to add in-room millwork and sinks and still meet the necessary regulatory and service requirements. This room can accommodate the transportation of patients into the scan area using wheelchairs, and provides access for crash carts and other emergency medical equipment on only one side of the table.

Sites considering a minimum room size may not have been designed with the structural requirements necessary to support the system and consequently may require upgrading prior to installation.

Customers considering a minimum room size should discuss their workspace requirements and future upgrade plans with their PMI, as the size and layout of these rooms often eliminates them from any future upgrade considerations and offers NO compatibility with future two-step installations.

If using the square meters (square footage) to determine regulatory compliance, please note that the front and rear cover clearances are wider than the regulatory clearance along the table length, and that the cover park position is behind the table in the home position.

Note: Sites must provide sufficient space to allow the removal of the rear cover, which is on wheels, from behind the gantry during service operations.



CAUTION

Operational Caution: In a minimum room layout (390 mm to 686 mm [15 in. to 27 in.]) the customer should consider workflow, customer access for patient care, and critical-care operations space requirements. Additionally, this room provides only limited equipment access on the gantry left side when loading patients or when positioning patient equipment in the room between the gantry and the wall.

Section 2.0: Suggested and Typical Room Layouts

Figure 6-1 and Figure 6-2 show the recommended and typical room layouts. You need to know the locations for medical gas, surface duct work, or other items that make a grounded wall.

Note: Your room layout may meet the recommended or typical room requirements but appear different than Figure 6-2 or Figure 6-5. Your salesperson can provide a detailed room layout for your site.

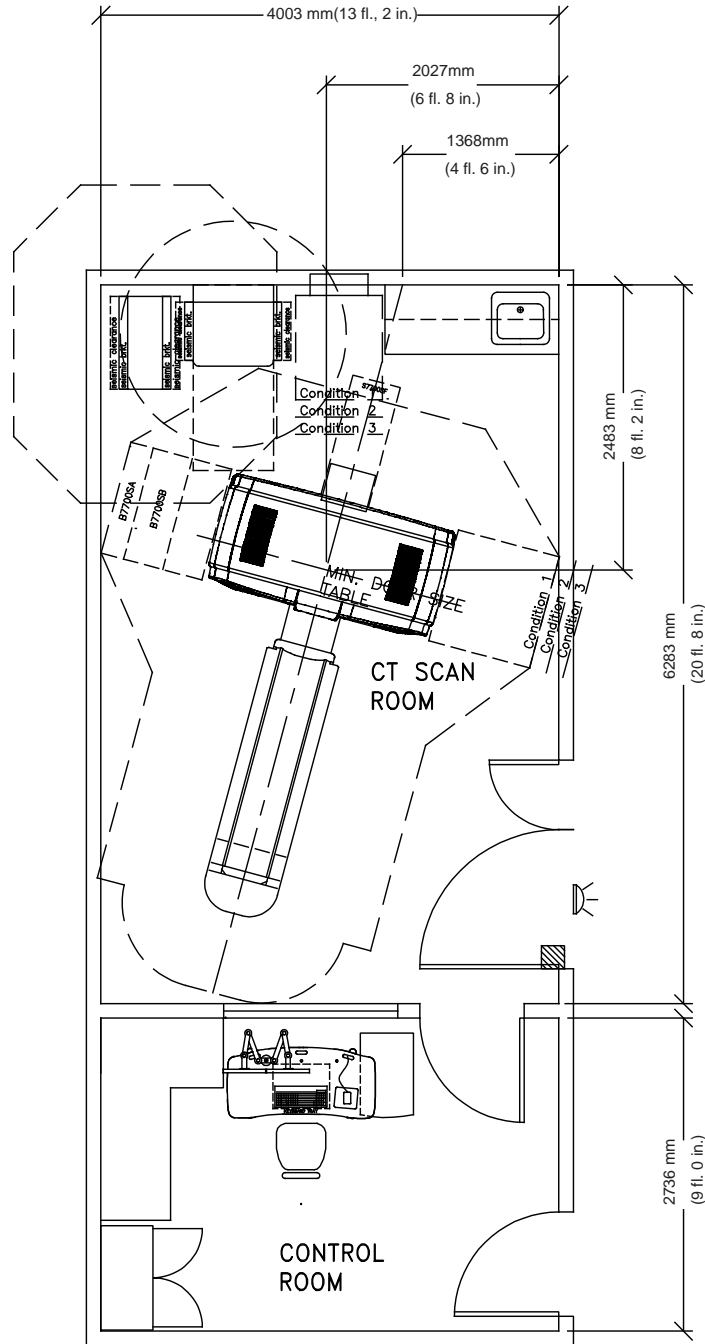

Figure 6-1 Suggested / Typical Room Size for Optima CT 660 w/ GT1700V Table

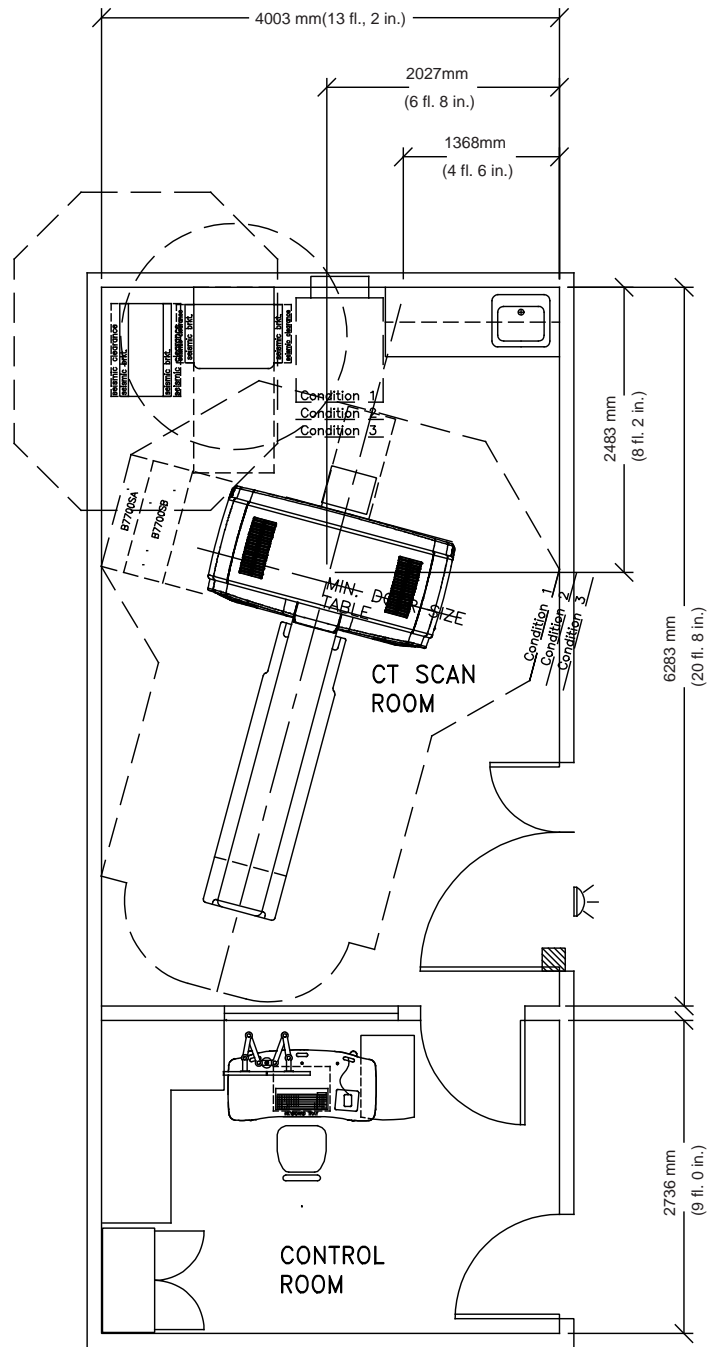

Figure 6-2 Suggested / Typical Room Size for Optima CT 660 w/ Lite Table

Section 3.0: Minimum Room Layouts

Three room layouts provide less than 711 mm (28 in.), but greater than 356 mm (14 in.) of space on the gantry left side, measured from covers to left-side wall, compromising service, egress, and workspace on the gantry's left side.

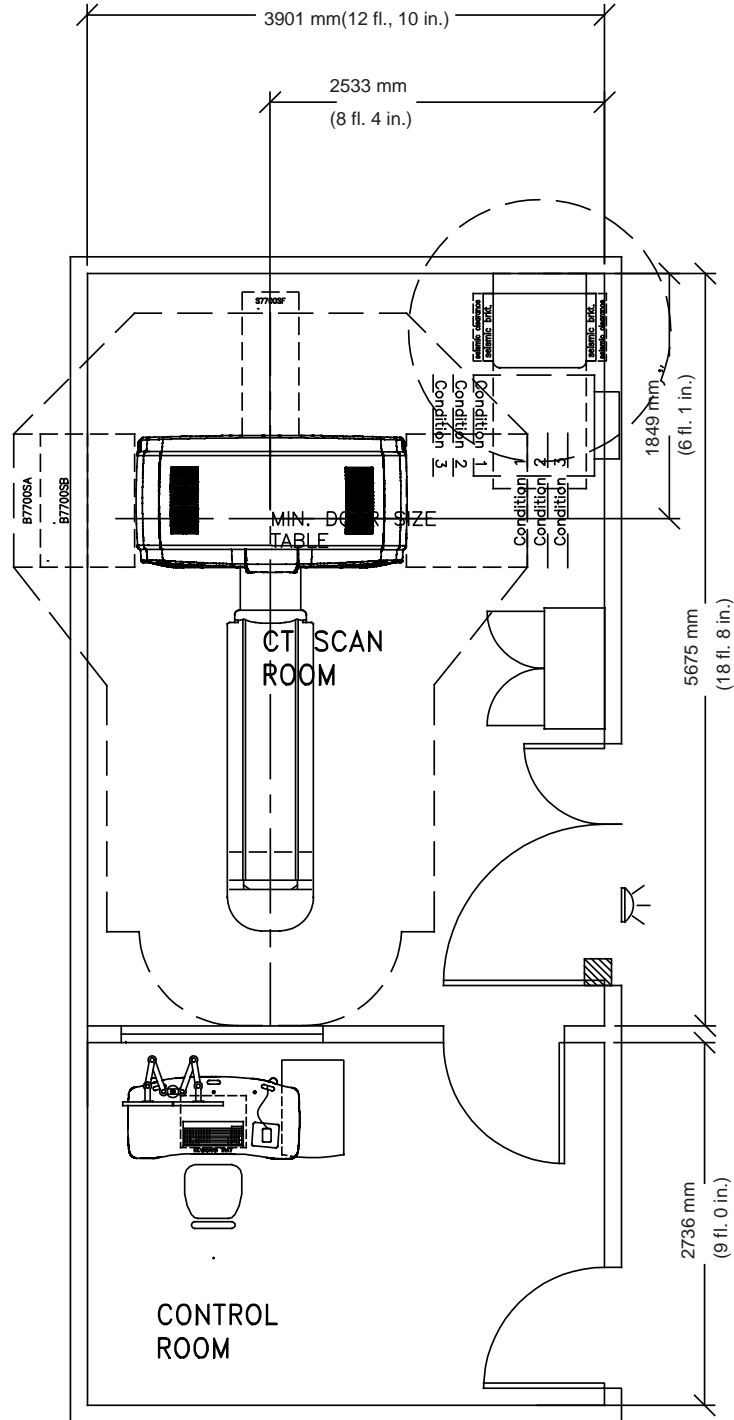

Figure 6-3 Minimum Room Size for Optima CT 660 w/ GT1700V Table

Note: This minimum room size does not allow for the UPS option or Surface mounted floor duct.

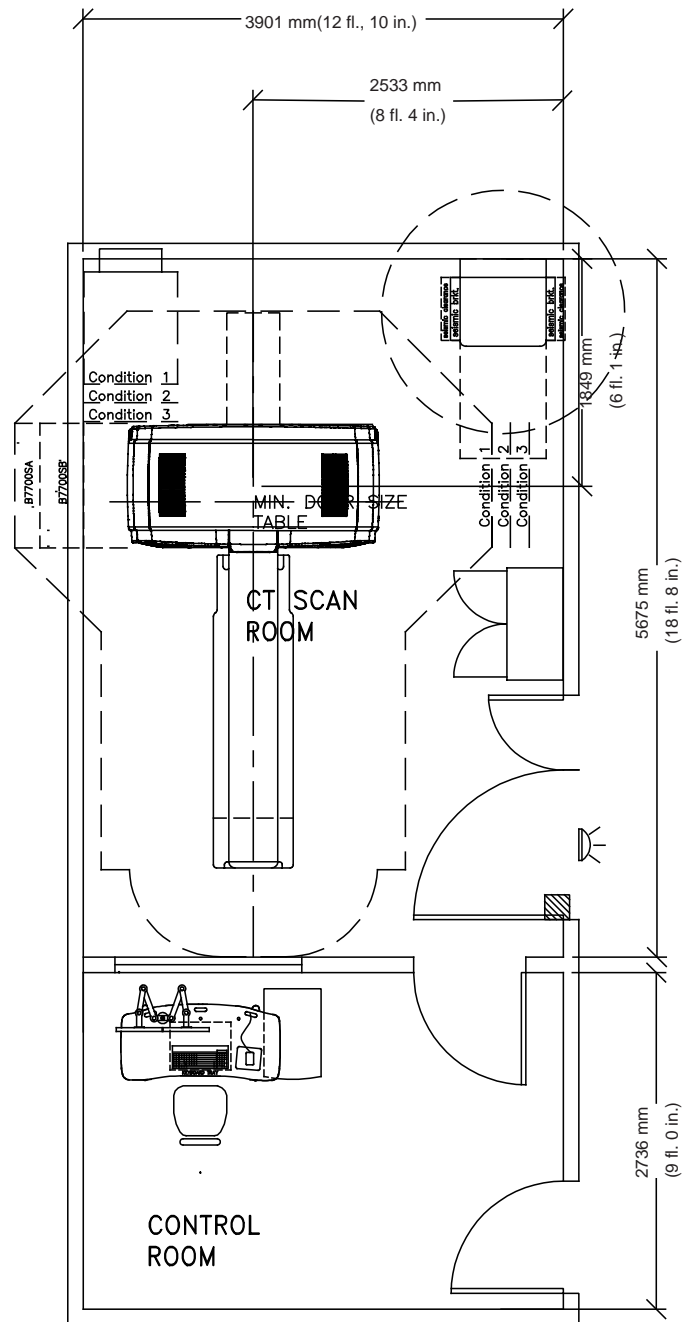

Figure 6-4 Minimum Room Size for Optima CT 660 w/ Lite Table

Note: This minimum room size does not allow for the UPS option or Surface mounted floor duct.

Section 4.0: Short Footprint Considerations

If the site room length cannot satisfy the requirements for standard mode. Short Footprint mode can be considered.

The Short Footprint mode limits the distance of the cradle travel so that cradle does not collide with the wall behind Gantry. The scannable range is limited accordingly.

The Short Footprint features are as follows:

- Cradle Movement limitation can be set at any position.
- Table height limitation cannot be set.
- Scannable range depends on the Gantry Rear space (distance to the wall), but need to consider the Service Clearance and country's local regulation for Gantry Rear space.

4.1 Instruction of using Short Footprint function



NOTICE

Cradle limitation must comply with country or local regulatory clearance requirements.

Cradle movement limitation set by short footprint mode must be approved by customer during pre-installation.

- 1.) Refer to [Figure 6-5](#), use floor template with ruler to prearrange the layout and calculate the cradle scannable limitation (A).
- 2.) Make GE siting print to meet regulatory and service clearance requirements.
- 3.) Record the distance from cradle limitation to wall (X) and cradle scannable limitation (A) for installation.

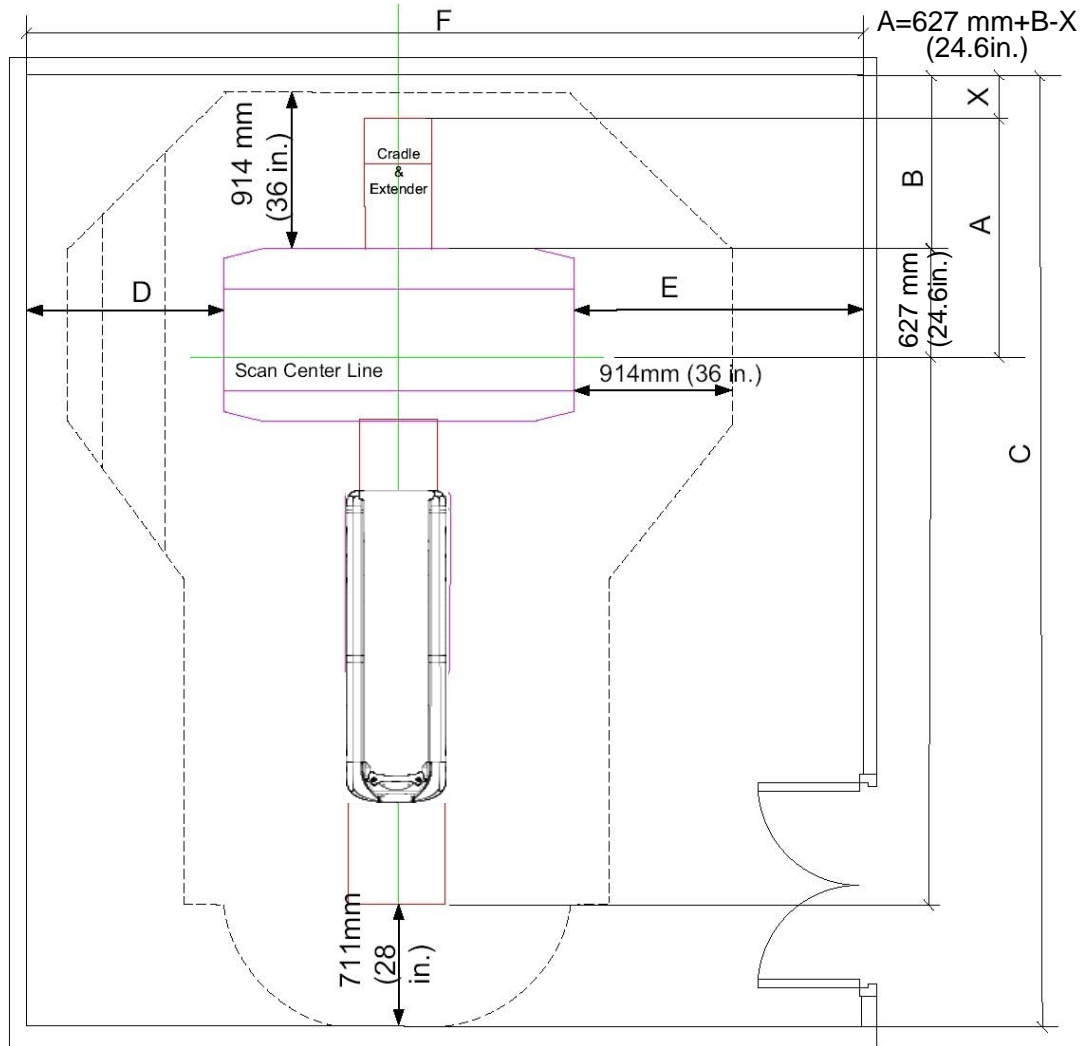

Figure 6-5 Short Footprint Calculation diagram

- A: Cradle Scannable Limitation, the value to be set using Short Footprint function
 $A(\text{Scannable Range}(\text{approx.})) = 627\text{mm (24.6in.) (Scan Center Line to Gantry Rear Cover)} + B(\text{Gantry Rear Cover to Wall}) - X(\text{Safety Clearance to prevent hitting cradle to wall}).$
- B: Gantry rear cover to wall, no less than 914 mm (36 in.)
- C: Room Length
- D: Gantry left side to wall, no less than 356mm (14 in.). Refer to Section 3.0 for details about Limited Access.
- E: Gantry right side to wall, no less than 914 mm (36 in.).
- F: Room Width
- X: Distance from cradle limitation to wall.



NOTICE It is suggested that safety clearance from cradle IN-limit to wall should be no less than 150 mm.

Section 5.0: Control Room Considerations

- The control room must provide an operating environment suitable for the console electronics and the operator's working comfort. See [Chapter 9, Environmental Requirements](#).
- As the console requires adequate venting, maintain 96 mm (4 in.) of clear, unobstructed space on all sides of the console to allow the four fans located on the rear of the console to exhaust air to both the left and right.
- Provide a suitable work area within reach of the console for the placement of the injector control. Injector controls differ in dimensions depending on the brand selected.
- A PACS, workstation, image printer, or filming device may appear in the console control room area. These devices or other components, though having a direct link to the console via network or ethernet cable, shall NOT receive power from the console (if outlets exist on the console). If you are using additional devices or components, consider additional room power and network connections when reviewing the console workspace.

5.1 Typical Control Room Layout

5.1.1 Console Considerations

- The console must remain in the same configuration as shipped. Do not dismantle the console, or remove or rearrange its components.
- Cable lengths must remain as shipped (cables cannot be cut or extended to mount the monitor on the customer's counter).

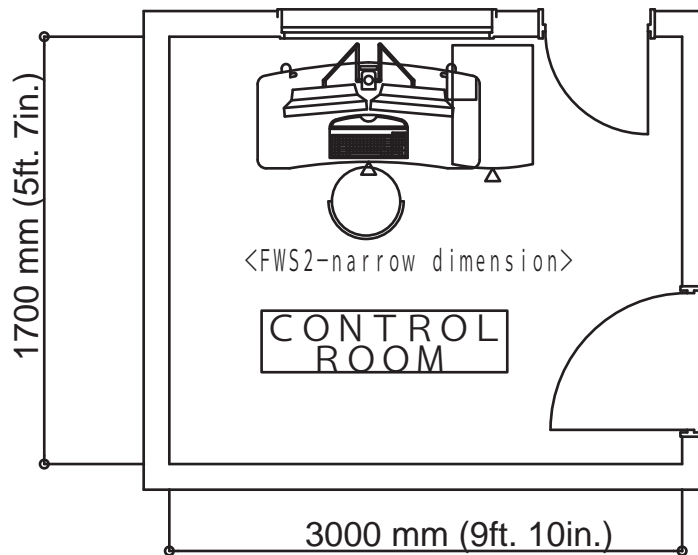
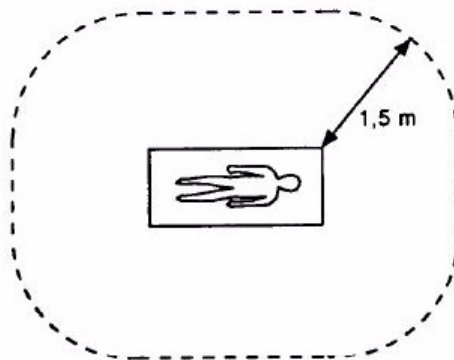
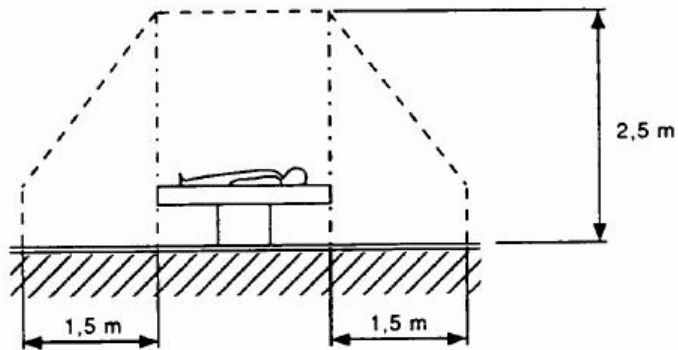

Figure 6-6 Typical Control Room Layout (Console with FWS Table)

Section 6.0: Patient Environment

The patient environment is defined as the following picture.



IEC 2513/2000

Only Scanning Gantry, Patient Table components and the following options can be placed in this area.

- Advantage 4D
- In room monitor
- SmartStep
- Extream Injector

Chapter 7

System Component Dimensions

Section 1.0: Minimum Operating Clearances

The sections in this chapter provide the minimum dimension and operating clearance information for each category of components listed. Be sure that the site conforms to each of these specifications.

1.1 Ceiling Pedestal Mount Installation

The distance from the floor to the lowest point of the ceiling pedestal mount for the Injector or Monitor CANNOT measure LESS than 2134 mm (84 in.). Refer to the installation guides of those components for the length of the mounting post.



NOTICE

Failure to maintain a distance of at least 2134 mm (84 in.) from the floor to the lowest point of the Injector or Monitor ceiling pedestal mount may pose a safety hazard. For installations with a finished ceiling height that is less than suggested, consideration should be given to utilizing floor mounted components, or attaching the mounting plate in the overhead (for example, above dropped ceiling tiles).

1.2 Injector Control Installation

Minimum dimensions and clearances include the following requirements for the injector control:

- Provision of a suitable work area for placement of the injector control, within reach of the console.
- Wall mounted, ceiling mounted, and pedestal units require routing of cables from the gantry area to the console area. The supplied cable measures 15.2 m (50 ft).
- Injectors require an AC power source that is powered from the console. The IEC power cord is supplied with the injector.
- Available mounts come in several different lengths and configurations. Refer to the injector documentation for detailed installation instructions.

Note: For RIO console systems, the console requires IEC power plugs to power GE approved options. All Options used with the system must be powered using the console or gantry power plugs. For systems using any NEC power plugs, Options (such as Video splitter) must be plugged inside the console power strip.

1.3 System Operational Clearances

The clearances listed in [Table 7-1](#) govern system operation; be sure that the site maintains each of these clearances.

System Operation	mm	inches
Ceiling Pedestal mount (optional) Lowest point to floor injector or monitor	2134 mm	84 in.
Finished ceiling to floor (suggested)	2743 mm	108 in.
Finished ceiling to floor (minimum)	2286 mm	90 in.
Table to maximum extension head end with extender from Center Line	1712 mm (GT1700V)	80 in.
	1537 mm (Lite Table)	61 in.
Table extension head end with extender to obstruction	150 mm	6 in.
Table in lowest position. with cradle at home position to Center Line	2744 mm (GT1700V)	108 in.
	2610 mm (Lite Table)	103 in.
Back of Console to wall	96 mm	4 in.
Back of PDU to wall	152 mm	6 in.

Table 7-1 Minimum Dimensions and Operational Clearances

Section 2.0: Component Dimensions

2.1 Gantry Dimensions

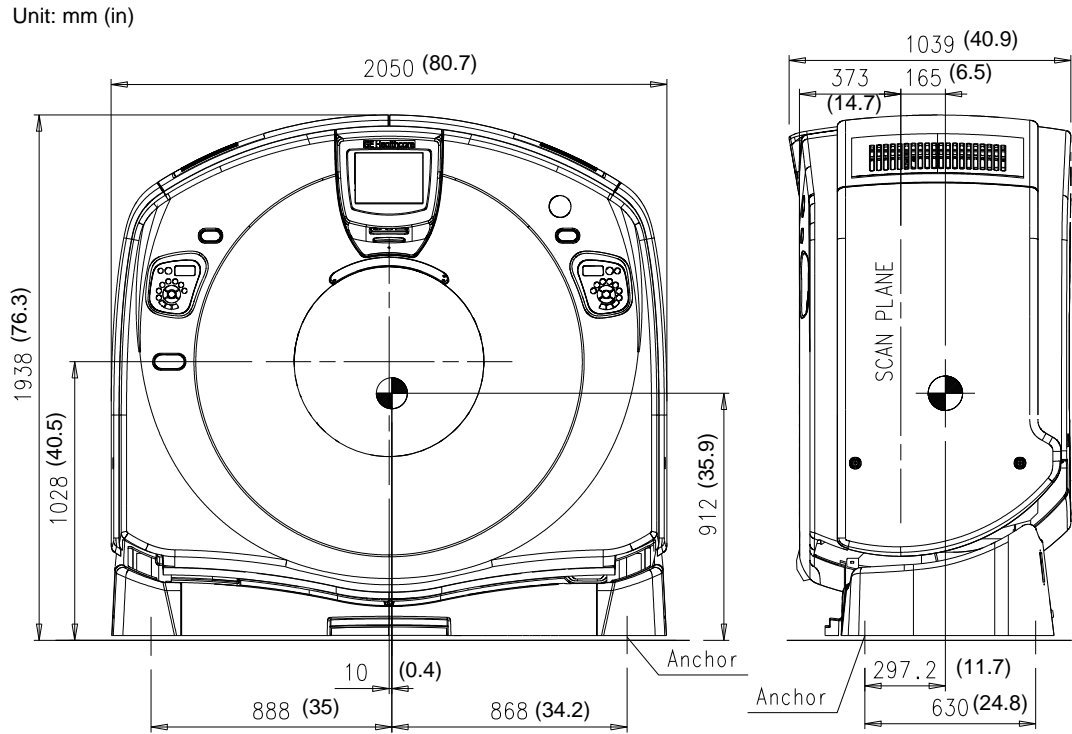

Figure 7-1 Gantry Dimensions with Covers

2.2 Table and Gantry Dimensions (with Lite Table)

Unit: mm (in)

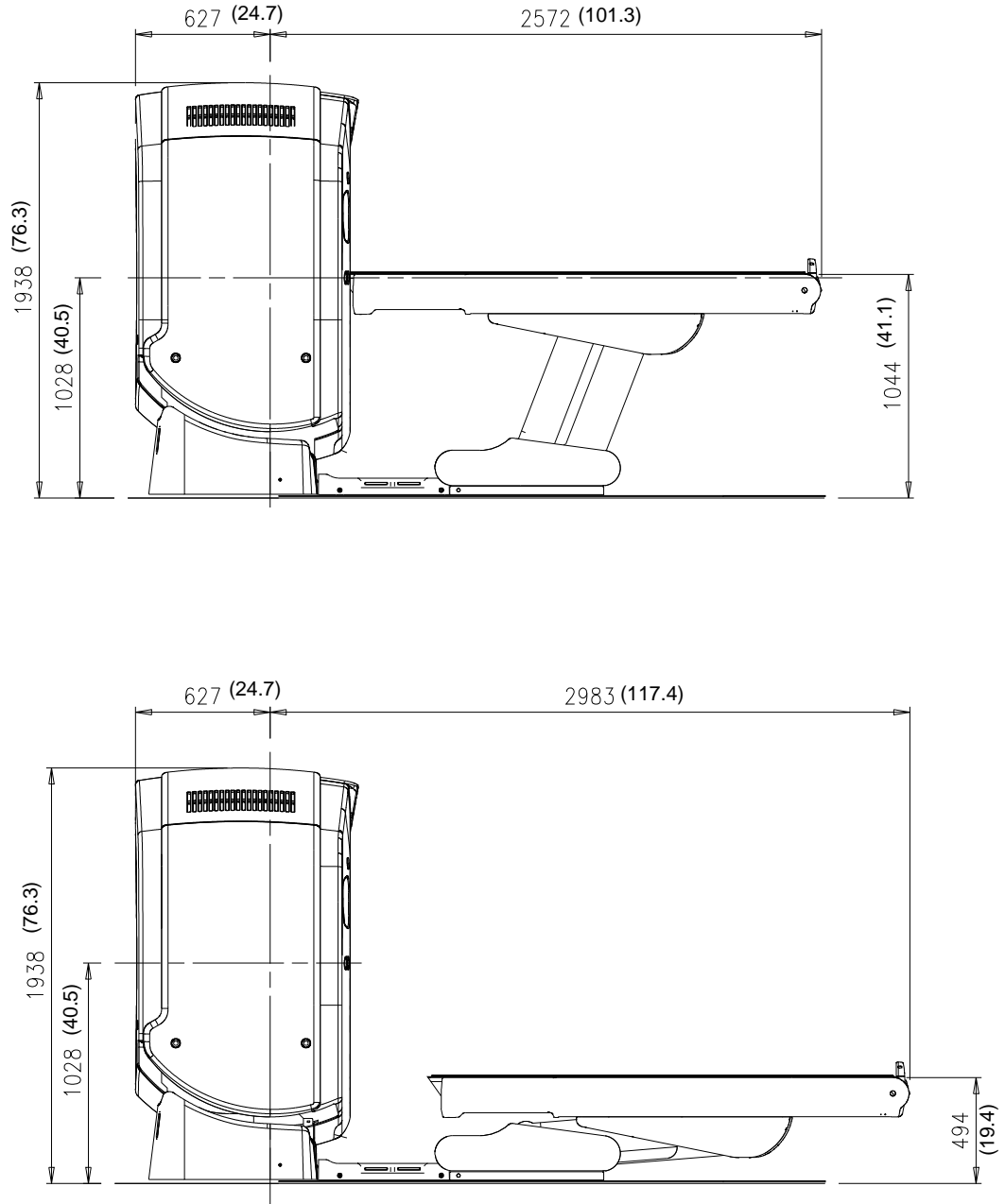

Figure 7-2 Lite Table and Gantry (Side View)

Unit: mm (in)

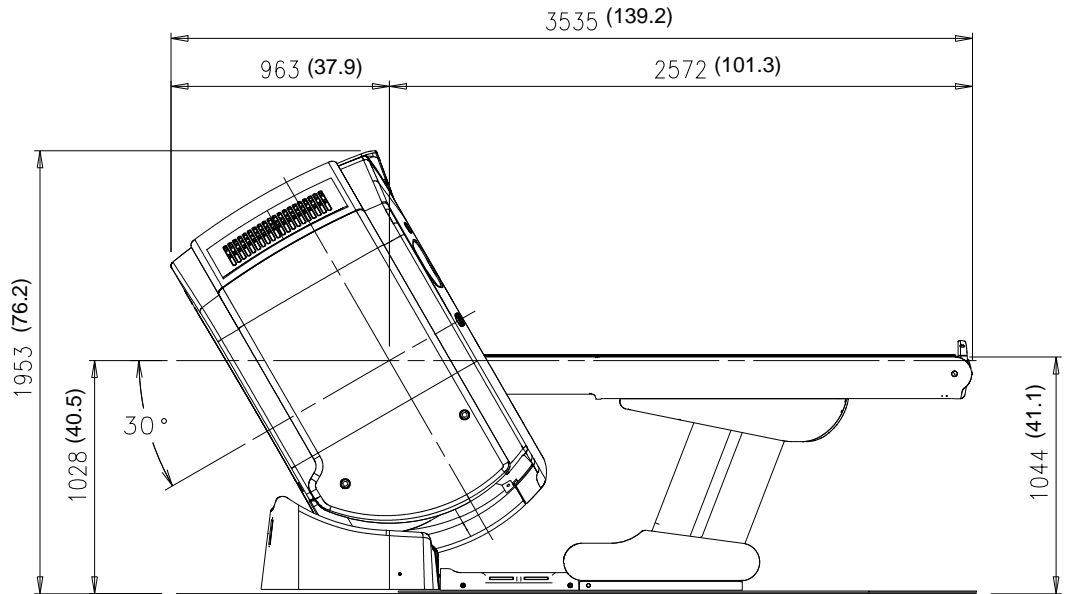
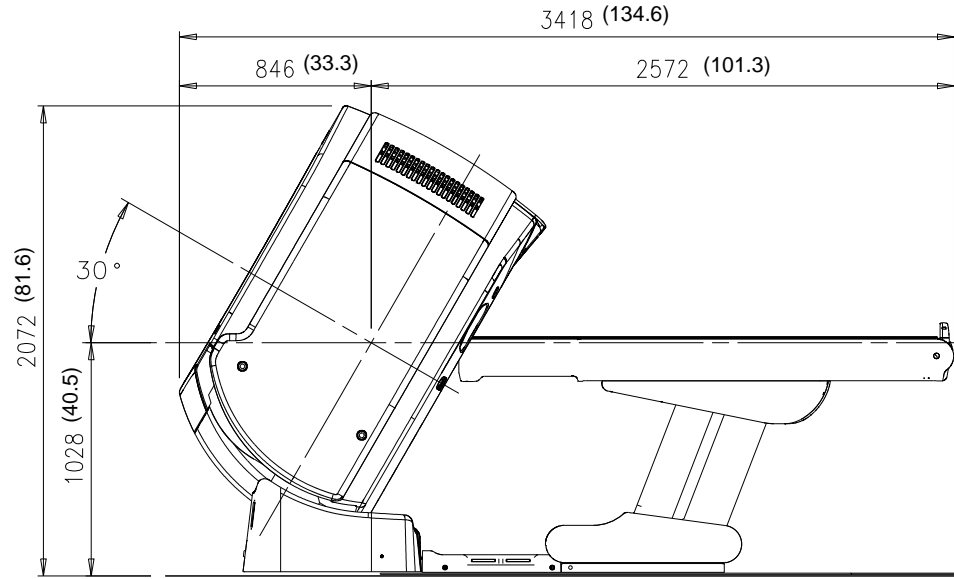

Figure 7-3 Gantry Tilted +30° (top) and -30° (bottom) - Lite Table Options

2.3 Table and Gantry Dimensions (with GT1700V Table)

Unit: mm (in)

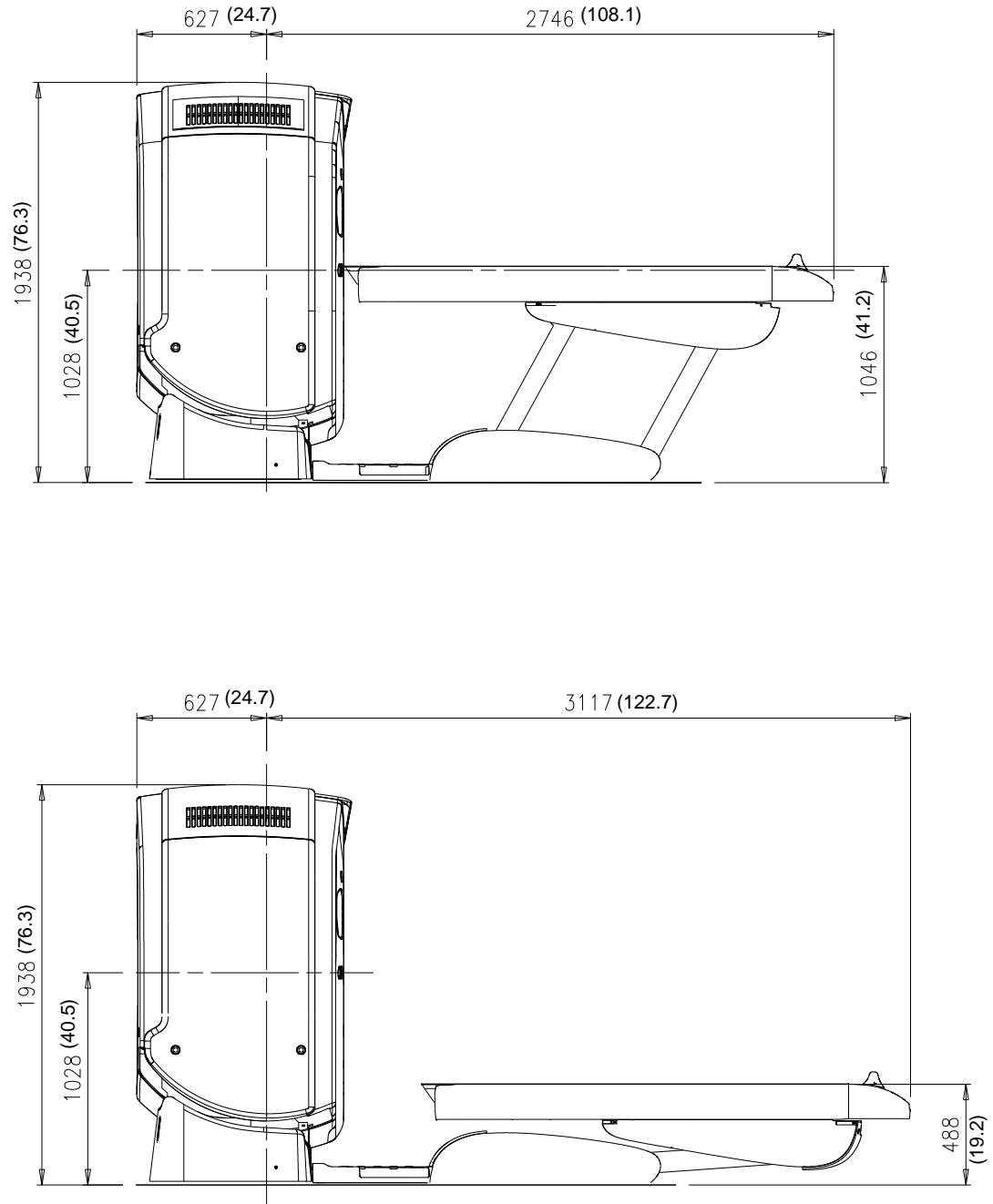

Figure 7-4 GT1700V Table and Gantry (Side View)

Unit: mm (in)

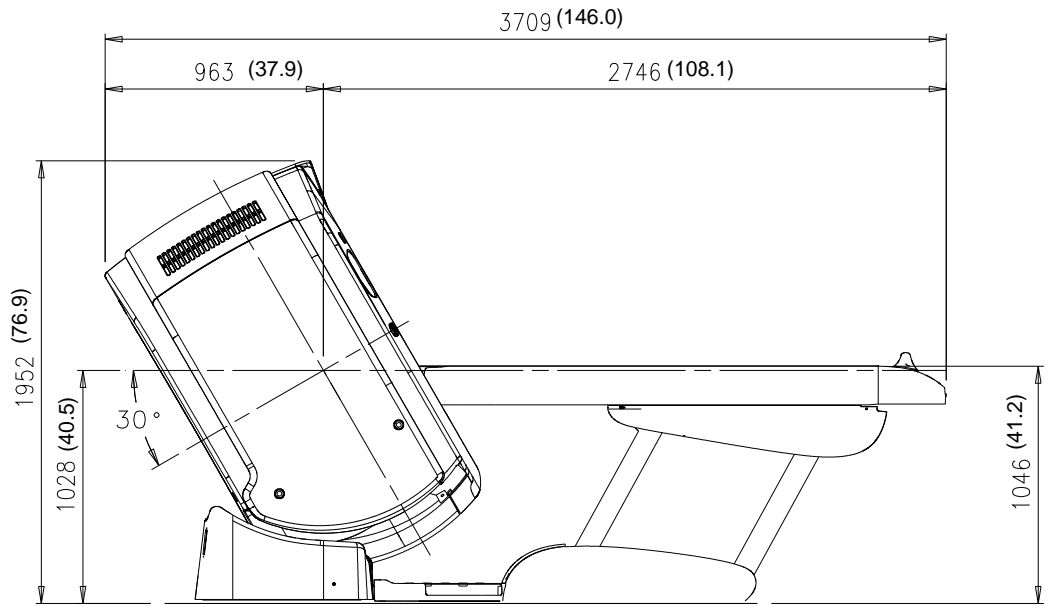
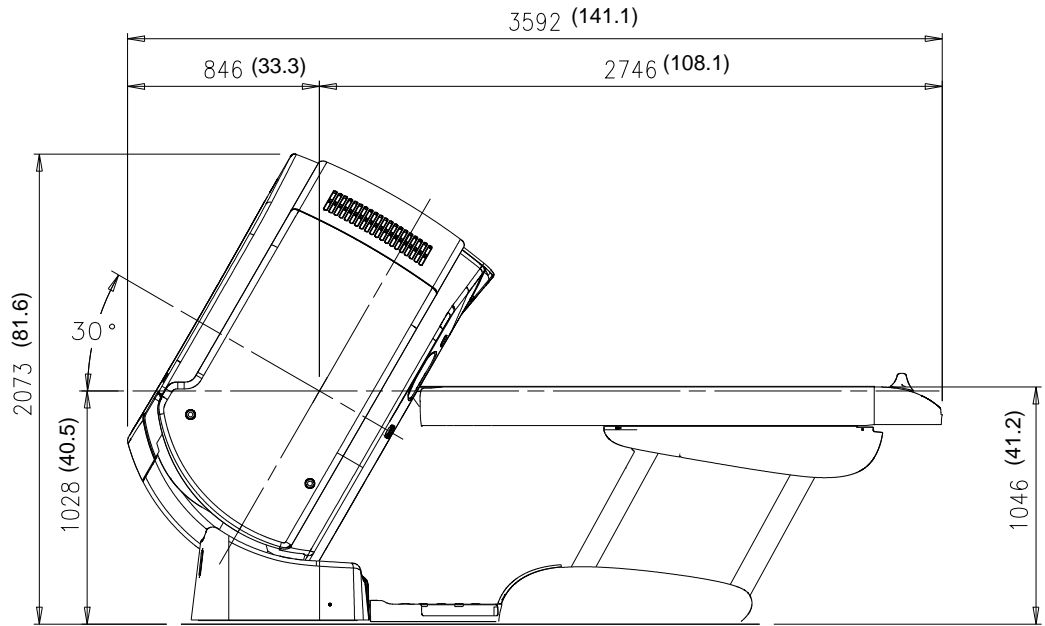

Figure 7-5 Gantry Tilted +30° (top) and -30° (bottom) - GT1700V Table Options

7 - Floor Loading

2.4 Power Distribution Unit Dimensions (PDU-80)

PDU dimensions, air intake/exhaust, seismic bracket locations, and service areas appear below.

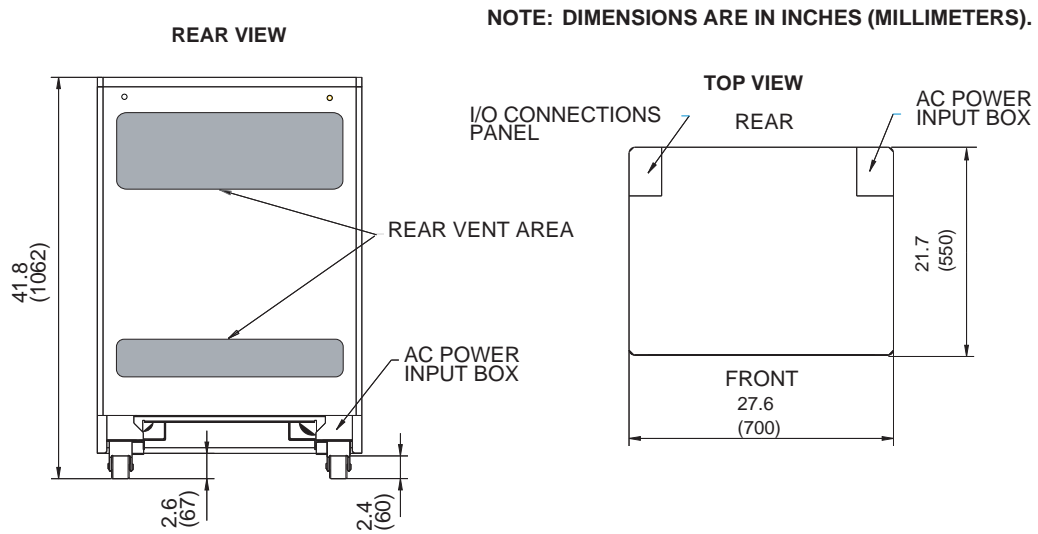

Figure 7-6 Power Distribution Unit

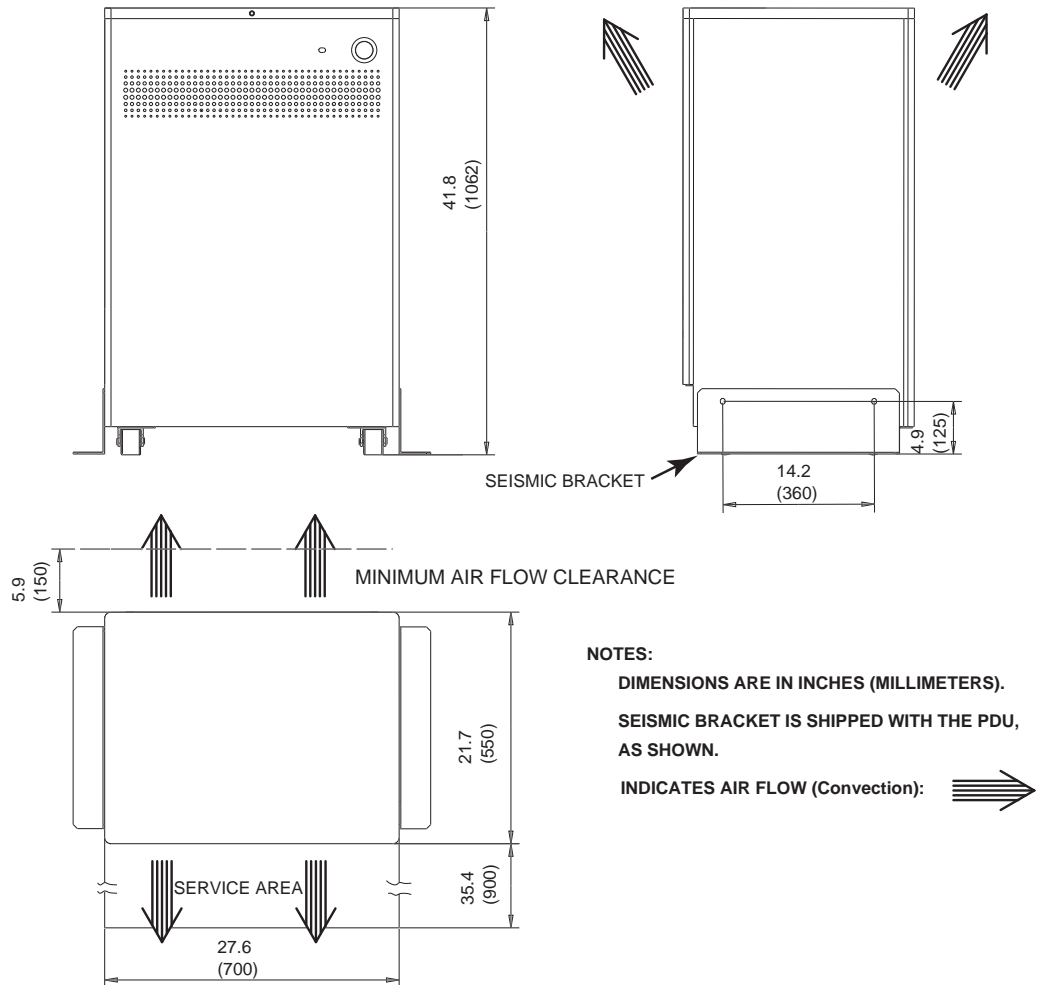

Figure 7-7 Power Distribution Unit

2.5 Console Dimensions

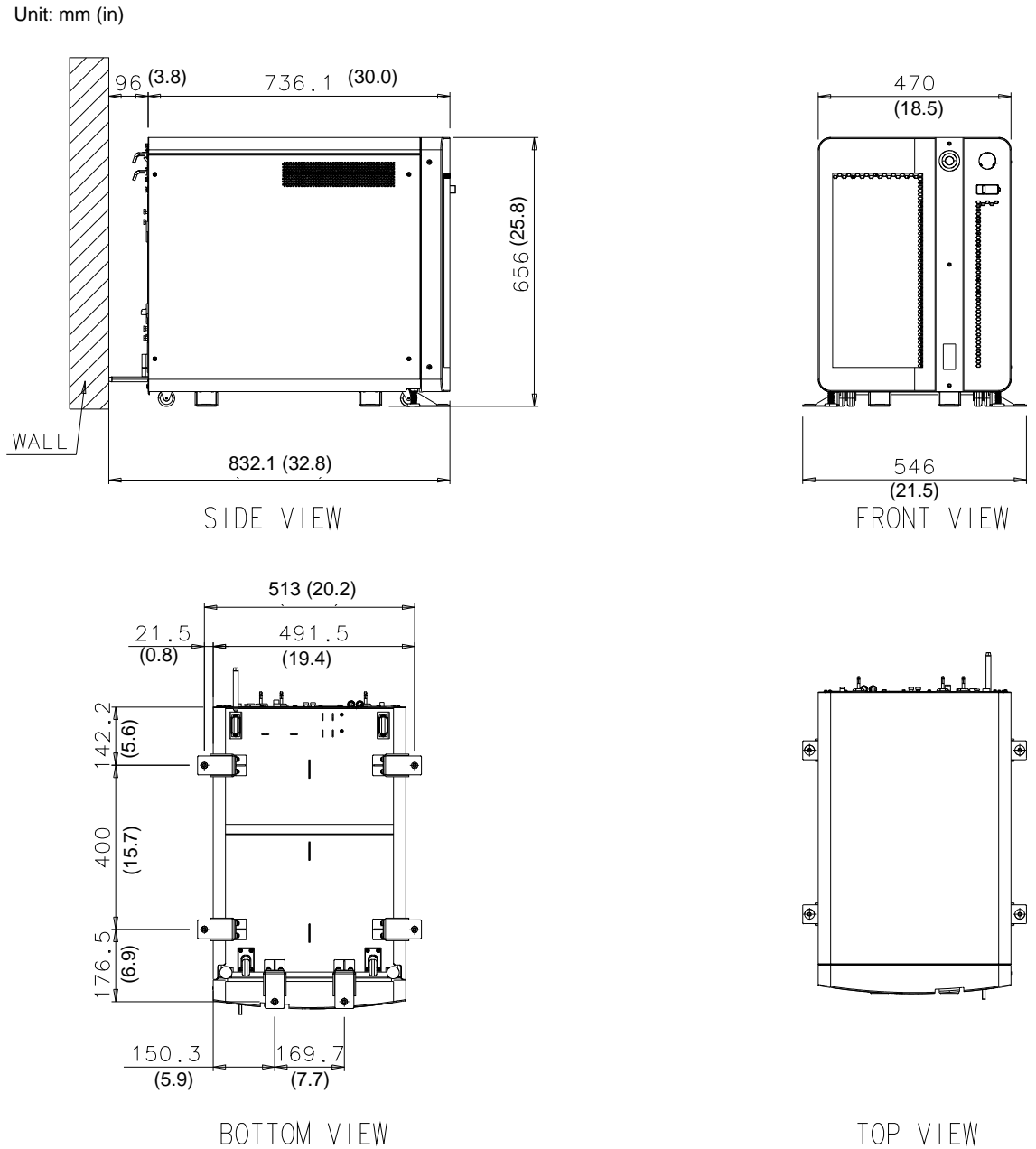

Figure 7-8 Operator's Console

7 - Floor Loading

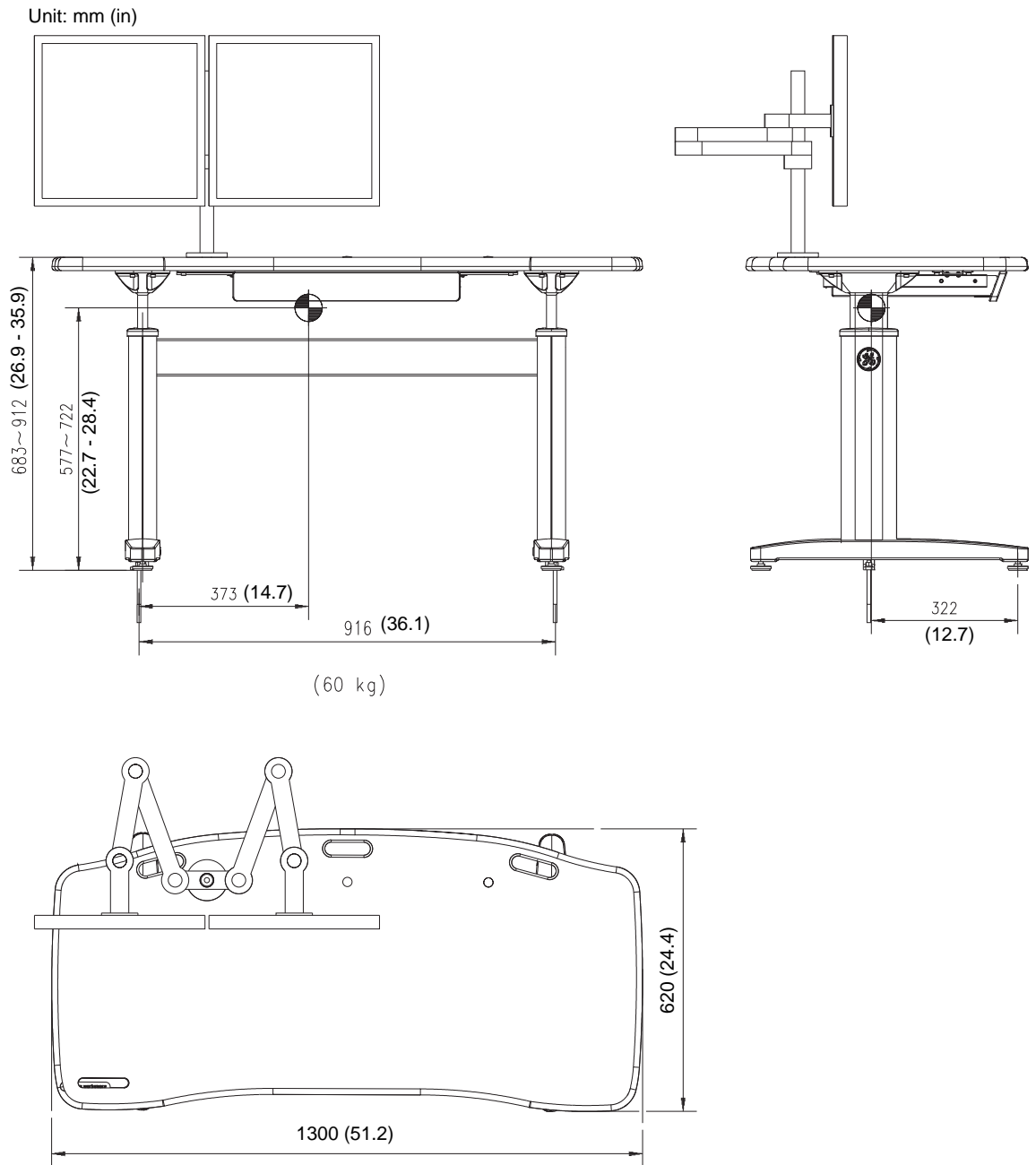

Figure 7-9 Freedom Workspace Table (part 5168666-3)

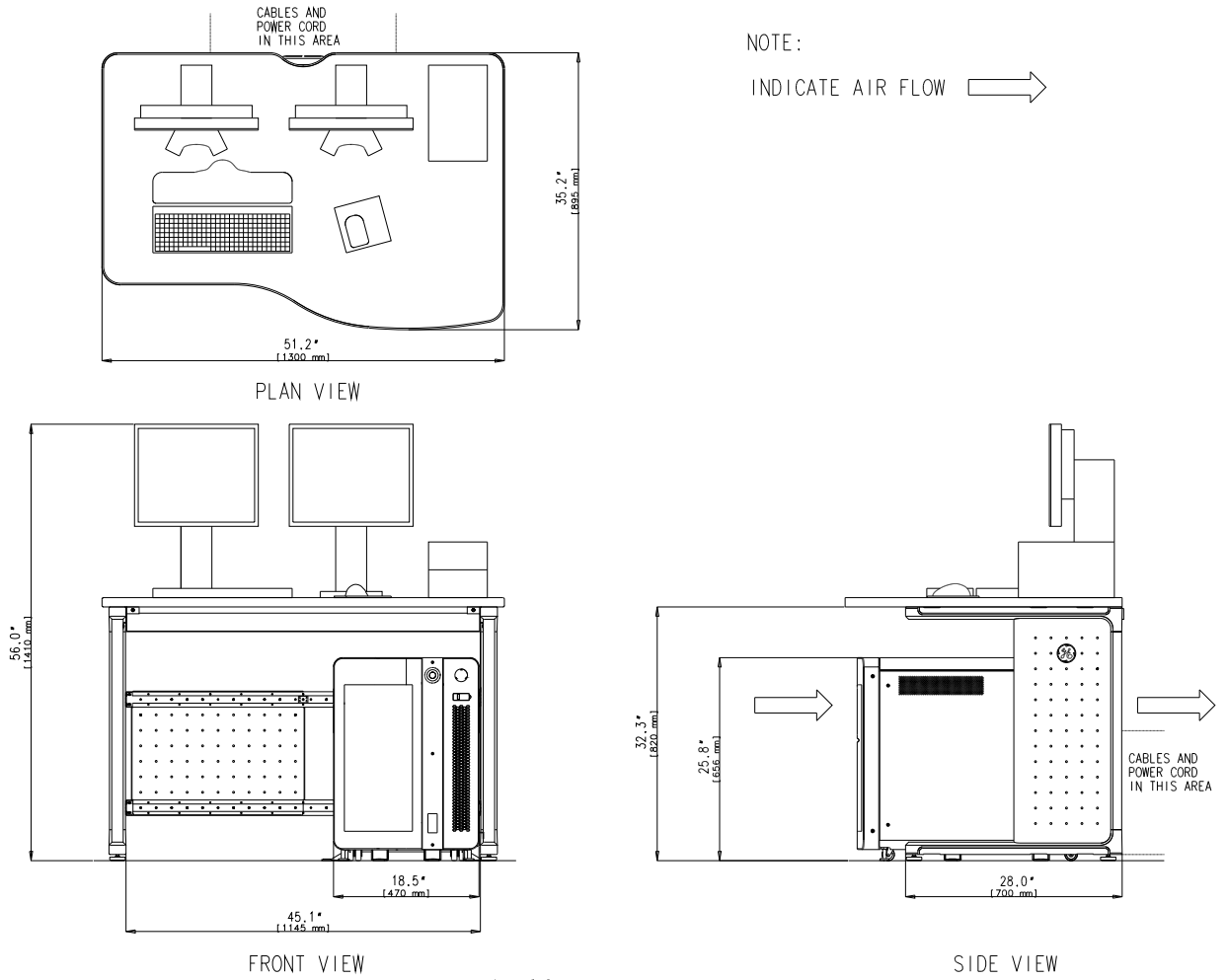

Figure 7-10 Cj Console with Optima Table

This Page Intentionally Blank.

Chapter 8

Structural and Mounting Requirements

Section 1.0: Overview

1.1 Importance of Meeting Structural Requirements

System performance specifications require close consideration of the customer's floor properties. The information in this chapter provides critical information and guidelines that the customer or PMI should communicate to the architect, structural engineer, and contractor prior to construction or renovation. Failure to properly evaluate the customer's floor and ceiling properties may result in limited performance and possible safety hazards.

1.1.1 Levelness, Vibration, and Floor Loading

All floors, whether configured to use the recommended GE-supplied anchoring system or an equivalent anchoring method, must meet the requirements for LEVELNESS, VIBRATION, and FLOOR LOADING listed in [Section 3.0 on Page 74](#).

1.1.2 Seismic Loading

Local laws and building codes in some areas may require the customer's contractor and structural engineer to consider seismic loads. [Section 6.0 on Page 83](#) provides the information necessary for the customer's contractor and structural engineer to complete the proper seismic calculations.

1.1.3 Anchoring

[Section 5.0 on Page 81](#) lists the information necessary for the customer's contractor or structural engineer to properly implement the GE-supplied anchoring system, if appropriate for the site. Please note that local laws, building codes, seismic considerations, and building or structural limitations may require the use of anchoring methods other than the GE-supplied anchoring system. In such cases, responsibility for providing an equivalent anchoring method rests solely with the customer's contractor or structural engineer.

Consult your architect, structural engineer, contractor, or PMI to resolve any questions.



NOTICE

Responsibility for providing an approved support structure and mounting method for all floor types, other than those listed in this chapter, rests with the purchaser. General Electric accepts no responsibility for any failure of the support structure or anchoring method, including seismic mounting and anchoring. GE accepts no responsibility for methods other than those listed.

Section 2.0: Ceiling Requirements

The minimum ceiling height above the table and gantry shall measure at least 2286 mm (90 in.) or the minimum distance allowed by local laws and codes, whichever is greater, when measured from the floor to the finished ceiling or to the ceiling pedestal mounts of any ceiling-mounted components. The purchaser or their contractor shall complete the installation of all pedestals for ceiling-mounted components. The PMI will provide the necessary bolt hole information upon request. The support structure for a ceiling-mounted option using a Mavig pedestal, requires a flush ceiling mounting

Detailed instruction for hole size and a template is available from Mavig or in their Portegra Installation Manual. Refer to [Figure 8-2](#).

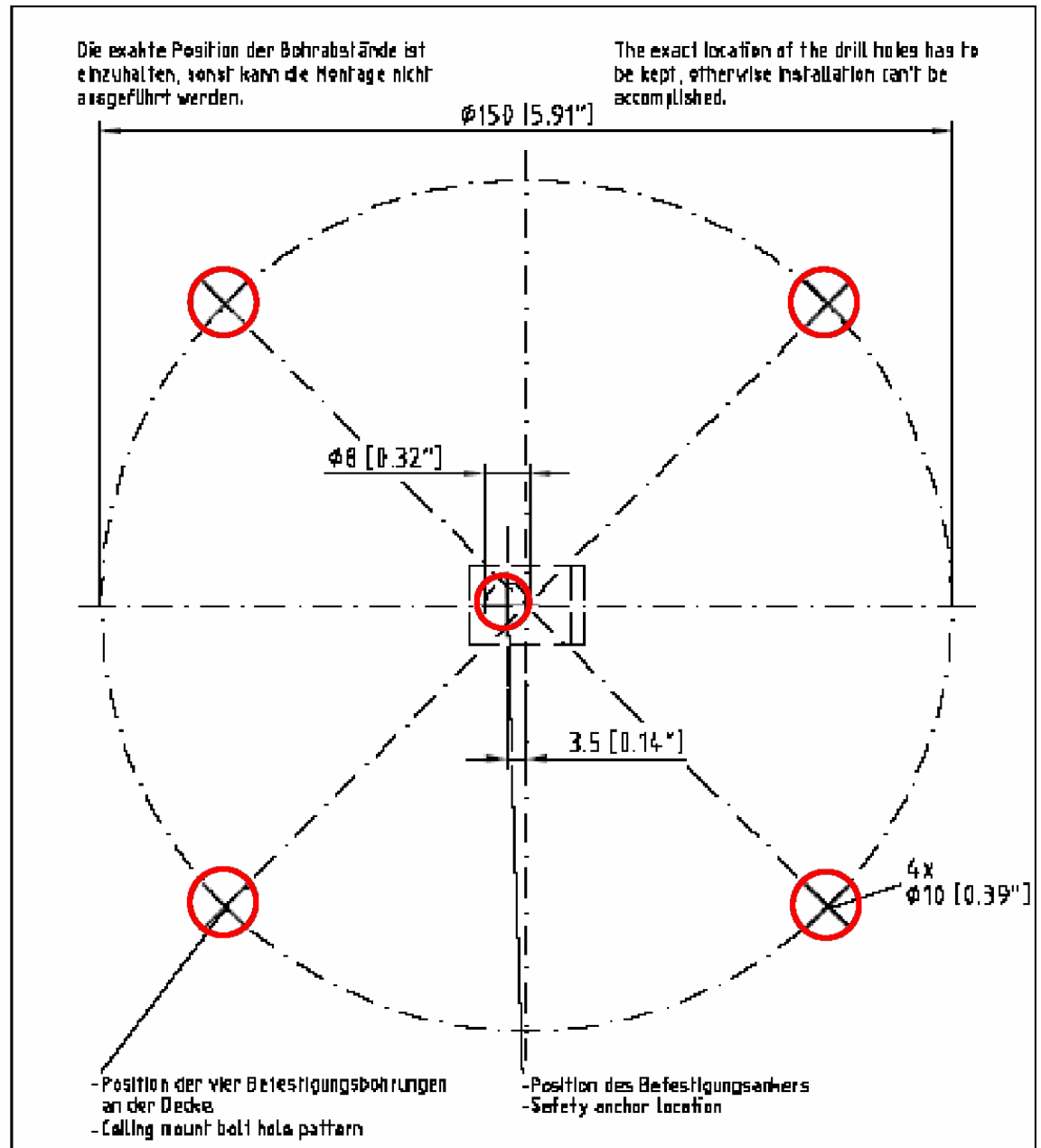

Figure 8-2 Mounting hole pattern for Mavig ceiling pedestal base

2.2 Pedestal Length Requirement

The pedestal-ceiling mount assembly must be installed at least 2134 mm (84 in.) from the lowest point to the finished floor.

2.3 Electrical Box Requirement

A 152 mm x 152 mm x 102 mm (6 in. x 6 in. x 4 in.) or equivalent ceiling box is required to be flush mounted next to the ceiling plate. There should be two (2) conduits exiting into the box and the box grounded to the mounted plate. The electrical box cover plate must be flush mounted to the finished ceiling and with provision to add a 102 mm x 102 mm (4 in. x 4 in.) centered GE-supplied electrical cover plate.

- Note:
- Additional mounting information is available on the Mavig website. Refer to the Protegra 2 Installation manual.
 - Seismic information is also available on the same website.

Section 3.0: Minimum Floor Requirements

3.1 Floor Levelness Specifications

3.1.1 Critical Specifications

Accurate patient positioning during scanning depends on proper alignment of the gantry and the table. The floor levelness specifications in [Table 8-1](#) ensure that the table and gantry height adjusters have enough range to allow proper leveling of the system.

Specification	Metric (minimum)	English (minimum)
Levelness	6 mm maximum variance over 3048 mm	1/4 in. maximum variance over 10 ft

Table 8-1 CRITICAL SPECIFICATIONS for Floor Levelness

3.1.2 Floor Levelness Guidelines

Consider the following factors when determining floor levelness:

- Factors that can disturb the levelness of a weak floor, including:
 - Moving weights such as gurneys or heavy personal equipment.
 - Changes in the system's center-of-gravity when the table moves, as the table can carry a patient load of up to 227 kg (500 lbs).
- Resilient tile, carpeting, or equivalent that may yield or compress over time. At sites with such floor coverings, be sure to cut away the tile or carpeting where the table and gantry adjusters touch the floor to expose the stable base material upon which to seat the adjusters.
- Floor shims are NOT PERMITTED.
- Refer to the steps listed in [Section 3.1.3](#) and to [Figure 8-3](#) to check whether the floor of the scan suite meets the floor levelness specifications for the system.

3.1.3 Measuring Floor Levelness

- 1.) Using the GE Floor Template (GT1700V: P/N 5341997, Lite Table: P/N 5193991) to establish the room layout and system location, locate the table and gantry anchor holes.

Note: To order a GE Floor Template (GT1700V: P/N 5341997, Lite Table: P/N 5193991), contact the GE Project Manager of Installation.

- 2.) Place the gantry template on the floor and align it according to the GE site print.
- 3.) Place the table template over the top of the gantry template, and align the scan and table centerlines.
- 4.) Secure the templates to the floor.
- 5.) Use a laser to check the levelness of the floor across the entire area covered by the template,

as shown in [Figure 8-3](#).

Note: If the floor is not level, your system cannot be properly aligned.

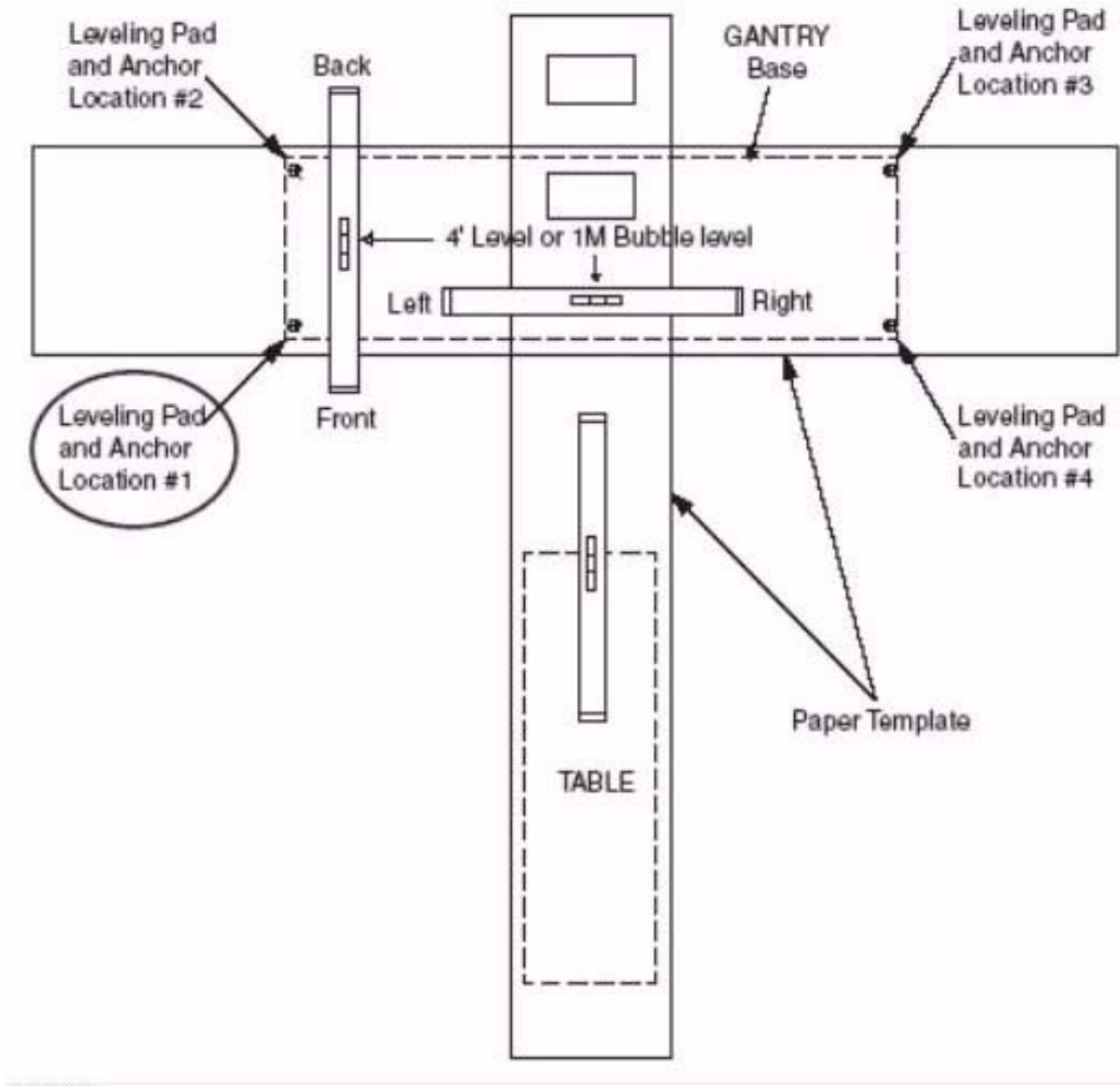

Figure 8-3 Determining Floor Levelness

3.2 Walls

3.2.1 Scan Window

The recommended patient viewing window dimensions are 1219 mm wide x 1067 mm high (48 in. x 42 in.). The location of the window is dependent on the position of the operator workspace position. Consult [Chapter 10, Radiation Protection Requirements](#) and a qualified radiological health physicist for radiation protection requirements of the window glass (lead content and thickness).

Note: The operator at the operator workspace must be able to view the patient during a scan.

3.3 Floor Vibration Specifications

3.3.1 Requirements

CT systems are sensitive to vibration and may display limited performance if exceeding the vibration limits listed below. The band of frequencies in which systems exhibit the most sensitivity appears at or near the resonant frequencies of the gantry and the patient table, the latter of which varies depending on patient mass and location. These frequencies fall within the following ranges:

- Patient Table: 2 - 10 Hz
- Gantry: 8 - 14 Hz

Floor vibration from any intermittent or continuous source, such as walking, running, exercising, mechanical equipment, and traffic, must not exceed the levels shown in Figure 8-4 or Figure 8-5, as represented by the solid line labeled CT system/Table. These figures compare this limit to the limits of what the AISC (American Institute of Steel Construction) and the ISO (International Organization for Standardization) call Class A (VC-A) and Class B (VC-B).

Note: In Figure 8-4 and Figure 8-5 the symbol μ represents 10^{-6} .

The preferred format for measuring vibration is velocity versus frequency, as shown in Figure 8-4. However, should it prove necessary to measure acceleration and there is no means to convert the measured data to velocity, then use the equivalent acceleration limit shown in Figure 8-5, derived from the velocity spectrum.

Frequency [Hz]	Acceleration [mm/s ² , rms]
4	2.5
10	2.5
12.5	3.1
16	5
80	25

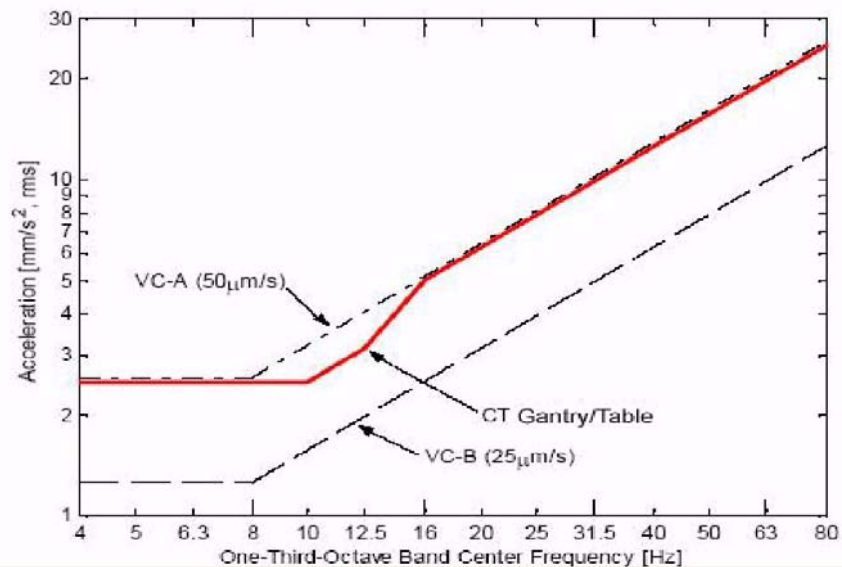

Figure 8-4 Allowable floor vibration in velocity units compared to ISO class A & B limits

Frequency [Hz]	Velocity [$\mu\text{m/s}$, rms]
4	100
10	40
12.5	40
16	50
80	50

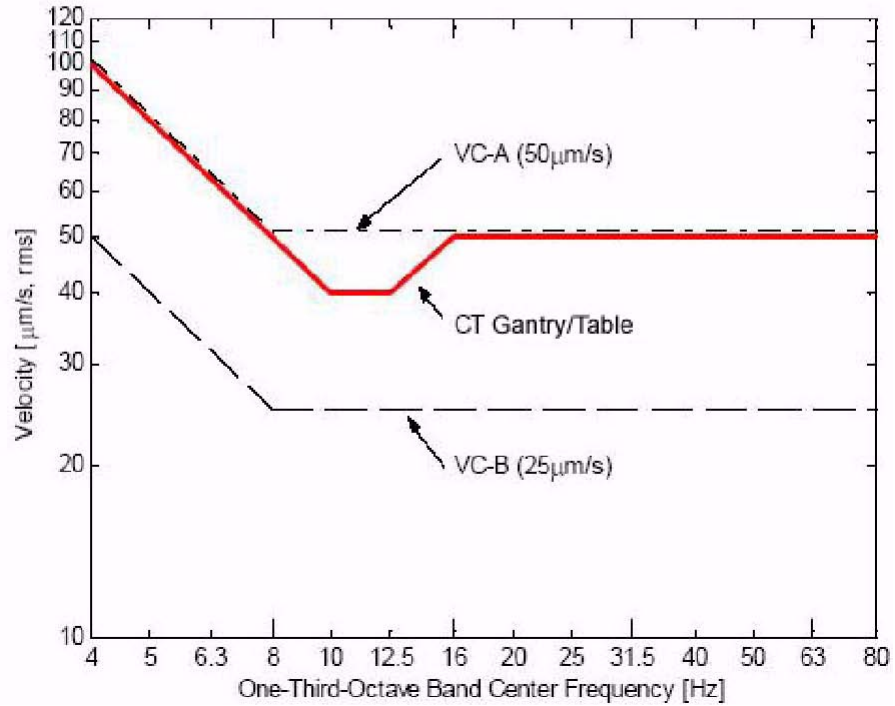

Figure 8-5 Allowable floor vibration in acceleration units compared to ISO class A & B limits

3.3.2 Sources of Floor Vibration

Consider that vibrations strong enough to affect the floor may emanate from the following sources in and around the scanning facility, requiring possible isolation of the floor or structure from them:

- Hospital power plants housing pumps, motors, air handling equipment, or air conditioning units
- Hallway foot traffic
- Elevators
- Parking lots
- Roadways
- Subways
- Trains
- Heliports

Section 4.0: Floor Loading and Component Weights

The customer's contractor and structural engineer should use the information in [Table 8-2](#) to help determine if the floor structure in the scan suite possesses sufficient strength to support the weight of the system.

System Component	NET Weight kg (lb)	Overall Width x Depth mm (in.)	Max Uplift Load N (lb)	Max Compressive load N (lb)	Supports mm (in.)
Gantry	1810 (3990)	2050 x 1039 (81 x 41)	0	4588 (1031)	Four round 64 mm (2.5 inch) pads in rectangular pattern.
Dollies (each)	114 (250)		0	4588 (1031)	
GT1700V Table with 227 kg(500 lb) patient	707 (1559)	660 x 4456 (26 x 175)	1455 (327)	4745 (1067)	Four round 64 mm (2.5 inch) pads in rectangular pattern.
Lite Table with 205 kg(450 lb) patient	525 (1157)	650 x 2347 (26 x 92)	2358 (530)	4972 (1118)	Four round 50 mm (2 inch) pads in rectangular pattern.
Power Distribution Unit (PDU-80)	370 (816)	650 x 2347 (26 x 92)	0	1070 (240)	Four casters
Console	80 (176)	470 x 736 (19 x 29)	0	318 (71)	Four casters
Monitor - LCD (each)	9 (20)	420 x 247 (16.5 x 9.7)			
Freedom Workspace (P/N 5168666-3)	44 (97)	1300 x 620 (51 x 24)			
Optima desk	57 (126)	1300 x 895 (51.2 x 35.2)			

¹**Note:** Loads provided for table support with patient in worst-case-scenario positioning.

Table 8-2 Optima CT660 Component Weight and Floor Loading Data

4.1 Floor Loading and Anchoring Guidelines

Follow the floor loading and anchoring guidelines below when preparing a site for system installation:

- The table and gantry require secure anchoring to the scan room floor. The power distribution unit and the console sit on the floor with casters; anchoring of these components to the floor is optional, unless required because of seismic considerations.
- For total floor load of a Optima CT660 with a GT1700V/Lite table and no UPS refer to [Table 8-2](#).
- When carrying the heaviest possible patient, the table-gantry-footswitch assembly represents a concentrated load within the scan room. Refer to [Table 8-2](#) for total weight.
- Anchors mount through the table and gantry supports. Use the floor template or its dimensions to locate the table and gantry support positions within the scan room, making sure that any anchors that pass through the supports clear all structural beams and interferences in the floor.
- If a loading analysis determines that the gantry and table position should change relative to their position on the GE site print, be sure to take into account the clearance requirements in [Chapter 4, Regulatory Requirements](#) and [Chapter 5, Service Clearance Requirements](#) when determining an appropriate location for the system.
- Hospitals and scanning facilities throughout the world may utilize a variety of floor types, and the disposition of different floor types may necessitate additional planning to adequately accommodate the system:
 - Wood floors often require substantial reinforcement. GE does not recommend using wood floors.
 - Temperature variation in blacktop or marble floors may allow anchor movement and pullout. GE does not recommend using these floors.
 - GE recommends using concrete floors with a minimum thickness of 102 mm (4 in.) for Gantry and GT1700V Table and 110 mm (4-1/3 in.) for Lite Table, when using GE-supplied anchoring or any other equivalent anchoring method.



NOTICE

Responsibility for providing an approved support structure and mounting method for all floor types other than the GE-recommended floor rests with the purchaser. General Electric accepts no responsibility for any failure of the support structure or anchoring method, including those used for seismic mounting. GE accepts no responsibility for methods other than those listed.

Section 5.0: GE-Supplied Anchoring

GE supplies anchors for mounting the table and gantry. The console and power distribution unit do not require anchoring to the floor. It is the responsibility of the customer to have a structural engineer and trained contractor use either the GE-supplied anchoring method or to provide an equivalent anchoring method to mount the table and gantry to the floor. Consult your architect, structural engineer, contractor, or PMI to resolve any questions.



WARNING

POTENTIAL FOR PATIENT INJURY!

AN IMPROPERLY SECURED TABLE MAY TIP, DISLODGING THE PATIENT. PATIENT SAFETY DURING SYSTEM OPERATION REQUIRES PROPER ANCHORING OF SYSTEM COMPONENTS.

5.1 Specifications of GE-supplied Anchors

Table 8-3 lists the specifications of GE-supplied anchors for the system. For a detailed view, including dimensions and additional specifications, see Figure 8-10.

GE-Supplied Anchors	Gantry/GT1700V Table	Lite Table
Part Number	2106573	2106573-3
Description	Hilti Kwik Bolt 2	Hilti Kwik Bolt 3
Diameter	12.7 mm (0.5 in.)	12.7 mm (0.5 in.)
Length	203 mm (8 in.)	140 mm (5-1/2 in.)

Table 8-3 GE-Supplied Anchor Specifications

5.2 Requirements for Using GE-supplied Anchors

Use of GE-supplied anchors (P/N 2106573, 2106573-3) shall adhere to the following requirements:

- Use the GE-supplied anchors ONLY when mounting components on concrete floors.
- Adhere to all anchoring requirements listed in Table 8-4.
- Any anchors showing more than 21 mm (~0.9 in.) of thread above the torqued nut requires the installation of a second anchor in the closest adjacent mounting location. The second anchor shall meet the same requirements in Table 8-4.
- Non-seismic installations must use a minimum of four (4) anchors to mount the gantry and four (4) anchors to mount the table.
- Fully engage the Adjuster Lock Rings (P/N 2106207) with at least one full thread showing below the notched portion on the Adjuster Screw.

Note: The table does not have the Adjuster Lock Rings shown in Figure 8-10.

Mounting Requirements	Gantry	GT1700V Table	Lite Table
Minimum Floor Thickness	102 mm (4 in.)	102 mm (4 in.)	110 mm (4-1/3 in.)
Recommended Drilling Depth	95 mm (3-3/4 in.)	95 mm (3-3/4 in.)	100 mm (4 in.)
Average Anchor Embedment	89 mm (3-1/2 in.)	89 mm (3-1/2 in.)	90 mm (3-1/2 in.)
Minimum Anchor Embedment	76 mm (3 in.)	76 mm (3 in.)	80 mm (3 in.)
Available Alternate Anchor Locations	Yes	Yes	Yes
Shipped Anchor Size	203 mm (8 in.)	203 mm (8 in.)	140 mm (5-1/2 in.)
Alternate Anchoring Methods	Yes (see note, above)	Yes (see note, above)	Yes (see note, above)
Floor Levelness Requirement	6 mm (1/4 in.) over 3 m (10ft)	6 mm (1/4 in.) over 3 m (10ft)	6 mm (1/4 in.) over 3 m (10ft)

Table 8-4 Table and Gantry Anchoring Requirements

- NOTES:
- 1) ANCHORS MUST BE EMBEDDED AT LEAST 125 MM [4.9 INCHES] FROM CONCRETE FLOOR EDGE OR EXPANSION JOINT
 - 2) TORQUE ANCHOR TO 75 N-M [55 FT-LBF]

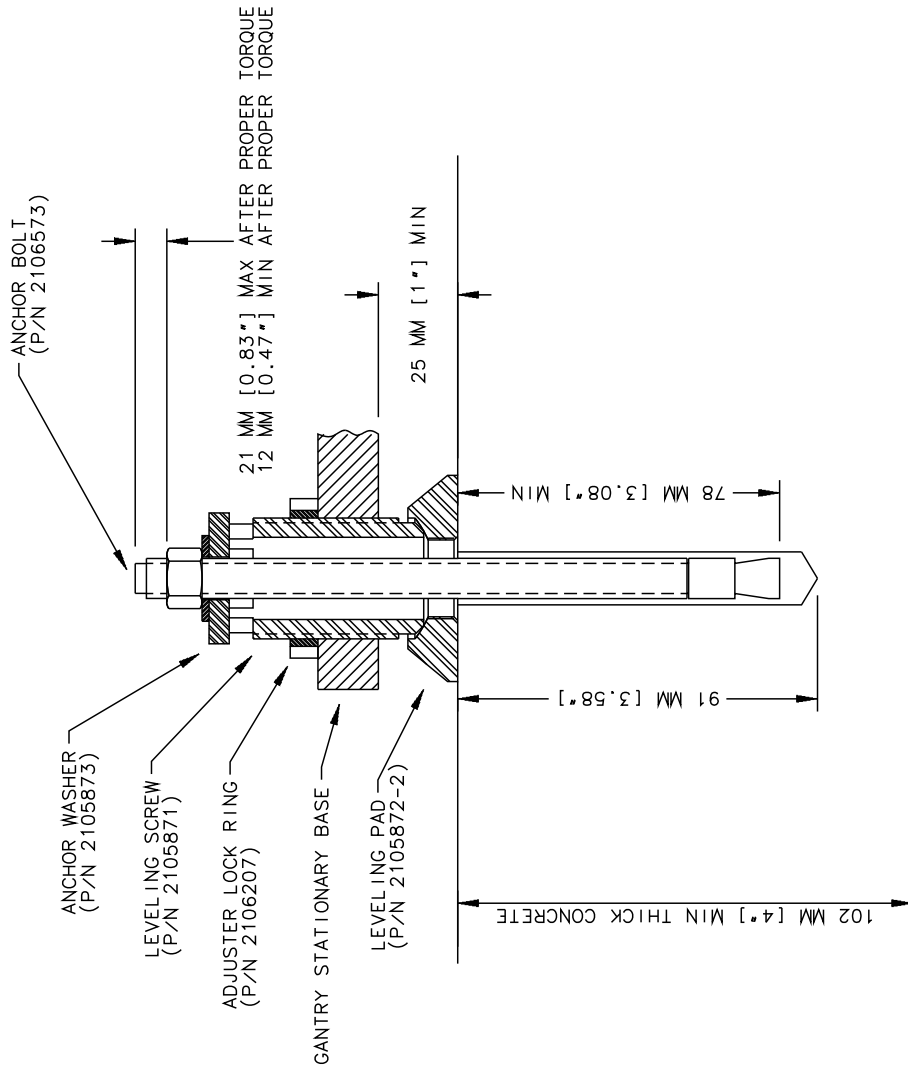

Figure 8-6 Gantry and GT1700V Table Anchoring

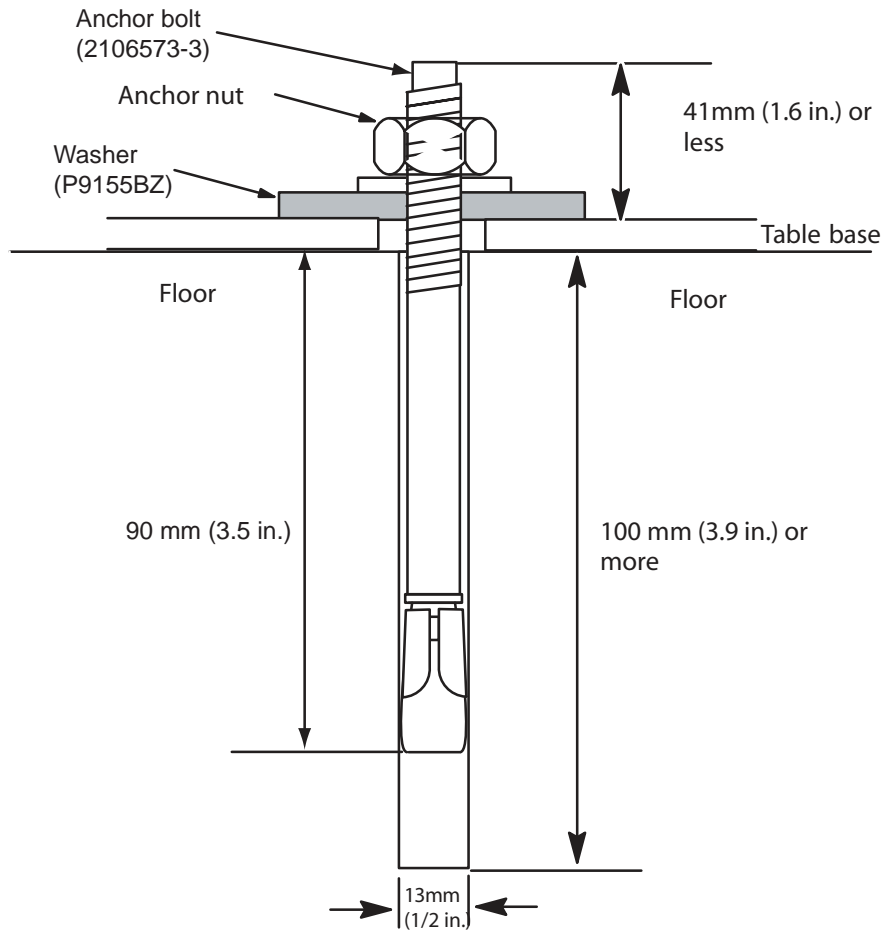

Figure 8-7 Lite Table Anchoring

Section 6.0: Seismic Mounting

6.1 Overview

Refer to the guidelines in this section when mounting the system in seismic zones:

- Responsibility for proper seismic mounting rests with the customer. Refer to all applicable laws and codes for your locality.
- GE-supplied anchors may not meet local seismic laws and codes. Use them only if a qualified structural engineer approves them for use in local seismic applications.
- The customer's contractor often supplies a state-certified print or equivalent, showing seismic installation instructions.
- Consider seismic requirements for ceiling-mounted fixtures and refer to the appropriate installation instructions for ceiling-mounted fixtures.

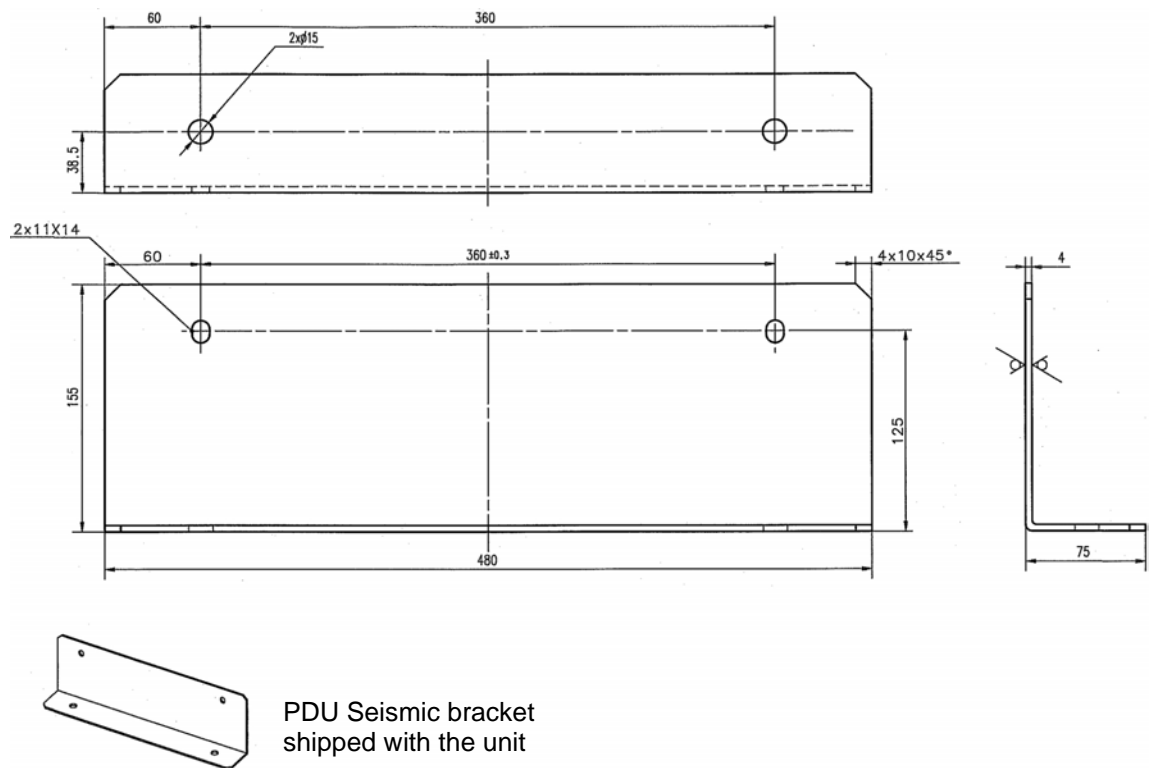

6.2 Center-of-Gravity Information

The information in the following figures provides the customer's contractor and/or structural engineer with center-of gravity information to assist in seismic calculations for the system:

- Gantry: [Figure 8-9](#)
- Table: [Figure 8-11](#)
- Power Distribution Unit: [Figure 8-12](#) (PDU Seismic Mounting Bracket)
- Console: [Figure 8-8](#)

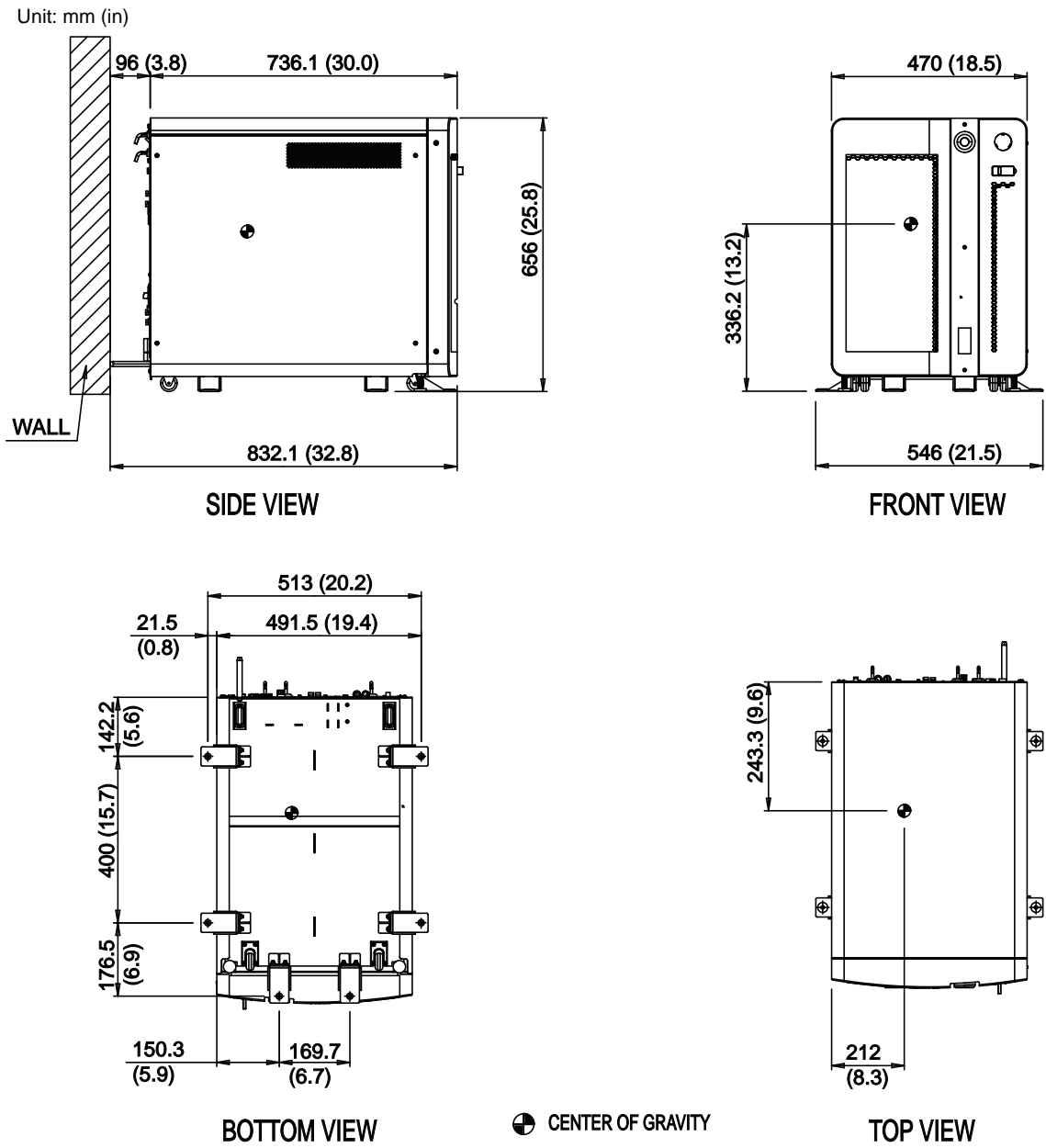

Figure 8-8 Console Center-of-Gravity

Unit: mm (in)

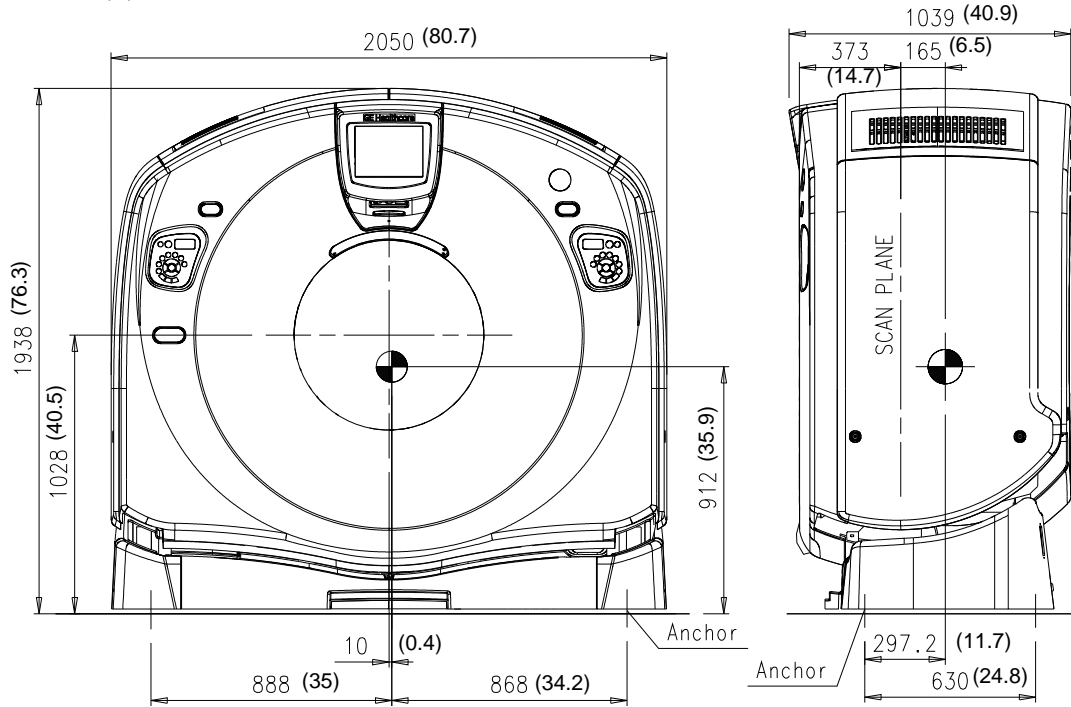

Figure 8-9 Gantry Center-of-Gravity

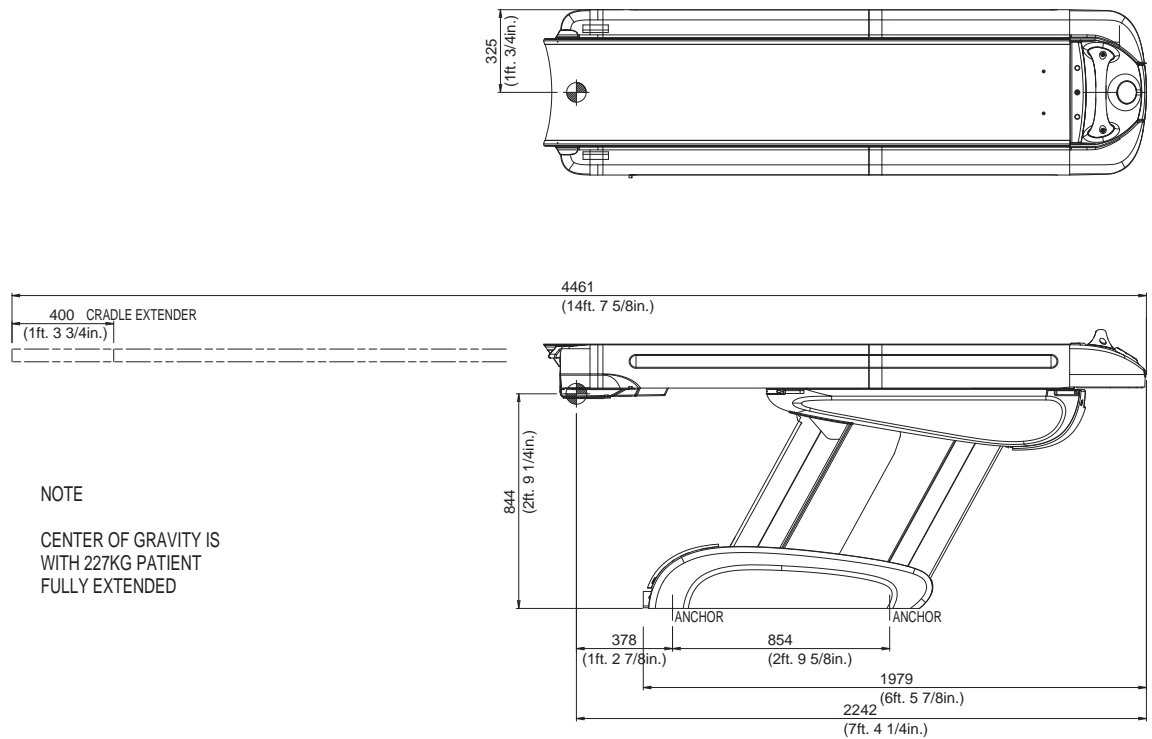



Figure 8-10 GT1700V Center-of-Gravity

8 - Delivery Data

- NOTES:
 * ALL DIMENSIONS ARE IN MILLIMETERS
 * VETALATION : 115 watts (100 kcal/h)
 *  INDICATES CENTER OF GRAVITY

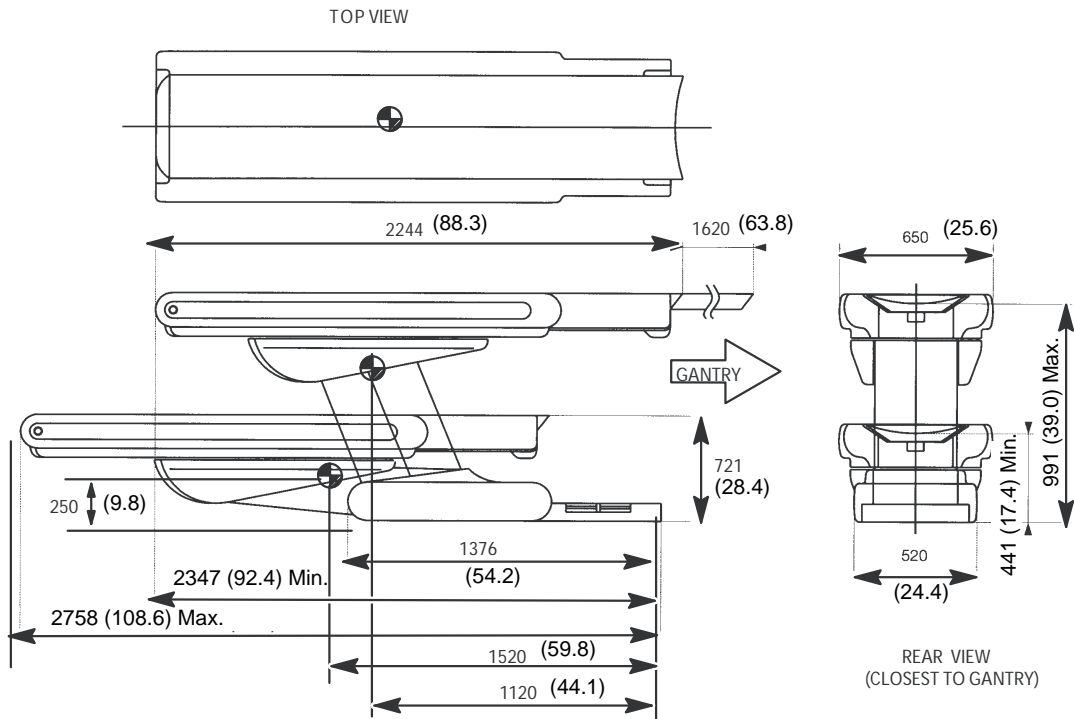

Figure 8-11 Lite Table Center-of-Gravity

Note: Center of Gravity location marked above includes the mass of a maximum weight patient on the table with a fully extended cradle.

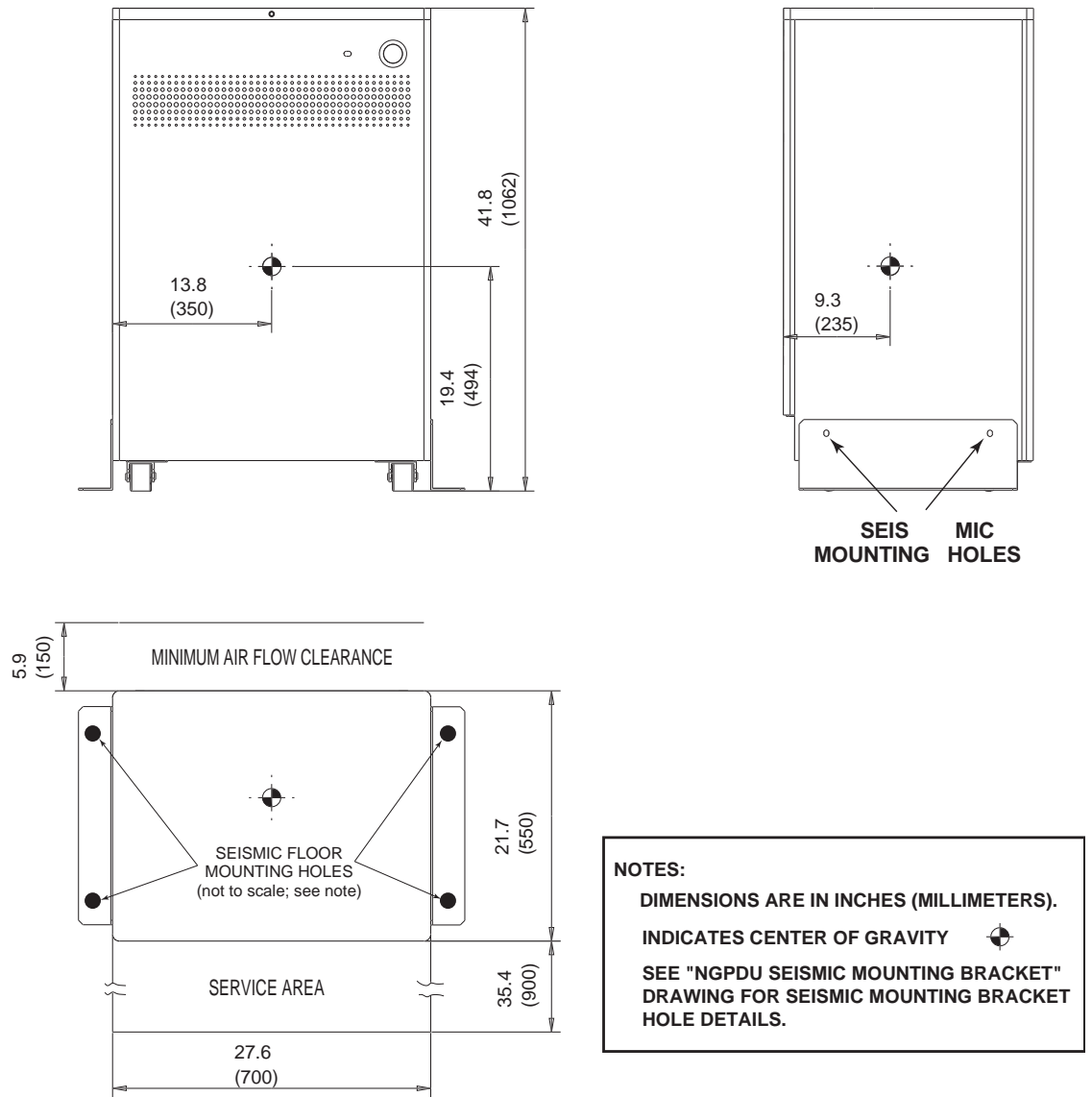

Figure 8-12 PDU Center-of-Gravity

This Page Intentionally Blank.

Chapter 9

Environmental Requirements

Ensure the operational readiness and proper system calibration of HVAC prior to installation. Maintain the environmental conditions listed below at ALL times, including over nights, weekends, and holidays. Shut down the CT system if air conditioning is not working. When shutting down the system for major repair, you may also shut down the air conditioning.

Section 1.0: Temperature and Humidity Specifications

Environmental specifications apply to the table, gantry, power distribution unit, and console.



NOTICE Exceeding environmental specifications may adversely affect system operation and image quality.

1.1 Temperature (Scan and Control Rooms)

Maximum allowable ambient room temperature:	26°C (79° F)
Recommended ambient room temperature:	22°C (72°F)
Minimum allowable ambient room temperature:	18°C (64°F)

Table 9-1 System Temperature Limits

Note: Be certain to account for ANY cooling equipment cycle control range, ensuring that the maximum and minimum ambient room temperatures do not exceed those shown in [Table 9-1](#) during room thermal cycling. For example, if the HVAC is capable of $\pm 2^\circ\text{C}$ control, then the limits would be $20^\circ\text{C} - 24^\circ\text{C}$ to maintain absolute limits.

1.2 Humidity (Scan Room & Control Room)

Maximum allowable non-condensing relative humidity:	60%
Minimum allowable non-condensing relative humidity:	30%

Table 9-2 System Humidity Limits

1.3 Other Guidelines

- Accurate determination of hospital room environmental conditions may require the temporary installation of a temperature and humidity recorder near the location designated for system installation. Record temperature and humidity readings before and after installation to verify the site's true environmental conditions.
- Consider heating, ventilating, air conditioning (HVAC) needs, and redundancy (back-up). An air conditioner with two compressor units rather than one, may prevent system downtime. A redundant (back-up) air conditioner permits CT system operation during an extended repair of the primary air conditioner.

Section 2.0: Cooling Requirements

Use [Table 9-3](#) to assist in cooling requirements planning. Gantry operation requires over half of the cooling utilized by your system. Contact an HVAC specialist to determine optimal placement of the thermostat and all HVAC vents, bearing in mind that:

- Gantry air INTAKE occurs across the BOTTOM of the gantry.
- Gantry air EXHAUST occurs across the TOP of the gantry.

System Component	Max BTU/HR	Max Watt
Gantry maximum (See Note 1)	18,700	5,480
Table		
GT1700V Table (1700mm)	1030	300
Lite Table (1400mm)	680	200
Power Distribution Unit	3400	1000
Scan Room Subtotal (w/ GT1700V Table)	23,130	6,780
Scan Room Subtotal (w/ Lite Table)	22,780	6,680
Console	2860	840
LCD Monitor (Total amount of 2 monitors)	340	100
Control Room Subtotal	3200	940
System Total (w/ GT1700V Table)	26,330	7,720
System Total (w/ Lite Table)	25,980	7,620

NOTE 1: Maximum heat output reached at tube change (Detailed Calibration).

NOTE 2: Heat output does not include heat from room lighting, personnel, or non-CT equipment.

Table 9-3 System Heat Output

Refer to [Figure 7-2](#), [Figure 7-4](#), [Figure 7-7](#), and [Figure 7-8](#) for component air flow requirements.

Figure 9-1 and Figure 9-2 show the recommended placements of the thermostat and HVAC vents (intake and output) for the scan and control rooms.

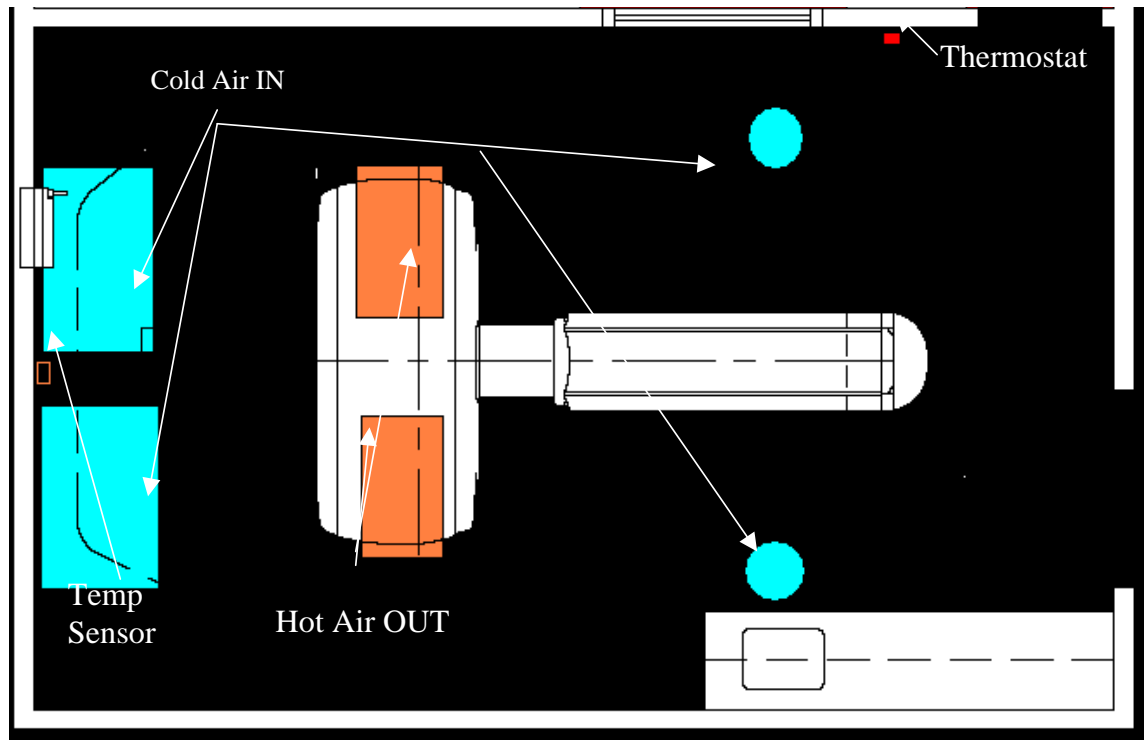

Figure 9-1 HVAC Air Vent Placement in Scan Room

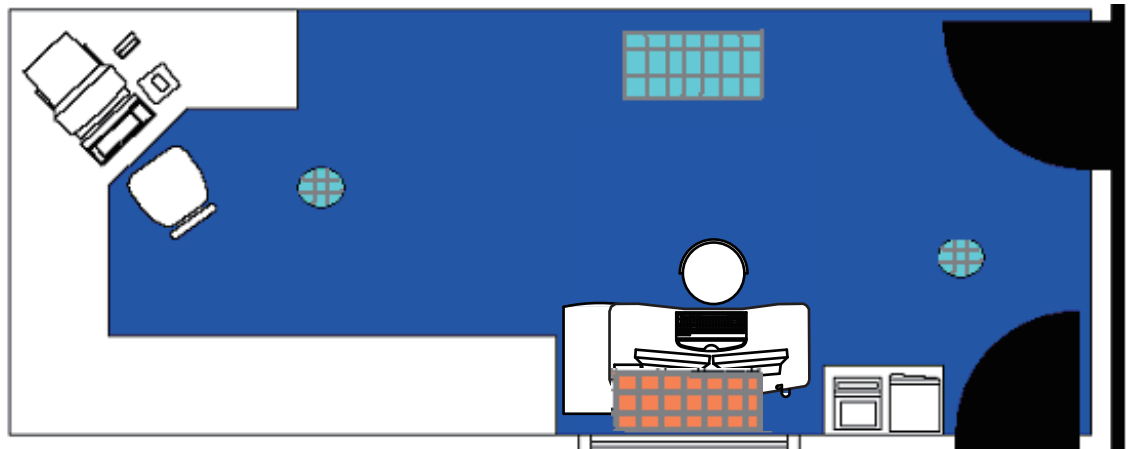

Figure 9-2 HVAC Air Vent Placement in Control Room

Section 3.0: Altitude

The system shall meet all functional and performance specifications when placed in a room that is at an elevation of -150 m to 2,400 m (-492 ft to 7,875 ft) above sea level.

Note: For sites with altitudes 2,400 m to 3,048 m (7,875 ft to 10,000 ft), you need a deviation to site a product at this altitude. Altitudes above 2,400 m (7,875 ft) require engineering approval.

Section 4.0: Electro-Magnetic Interference (EMI)

4.1 Gantry

Locate the gantry in ambient static magnetic fields of less than 10^{-4} tesla (500 milligauss) to guarantee the specified imaging performance. Ambient AC magnetic fields must measure below 10^{-6} tesla (10 milligauss) peak.

4.2 Console / Computer Equipment

Locate computer equipment in ambient static magnetic fields of less than 10^{-3} tesla (10,000 milligauss) to guarantee data integrity (see [Figure 9-3](#)).

4.3 PDU

The PDU produces an electromagnetic field that radiates outward from its cabinet in all directions. Do not place the gantry or patient table within 0.3 meters (12 inches) of the edge of the Power Distribution Unit. Do not place other sensitive electronics (e.g. the operator console or computer equipment) within 1.0 meters (39 inches) of the edge of the Power Distribution Unit in any direction, including above or below it. The UPS is not classified as sensitive electronics. (see [Figure 9-3](#)).

4.4 EMI Reduction

If you know of or suspect the presence of fields of excessive EMI, consult GE Healthcare Sales & Service for recommendations. Consider the following when attempting to reduce EMI:

- External field strength decreases rapidly with distance from source of the magnetic field.
- External leakage magnetic field of a three-phase transformer measures much less than that of a bank of three single-phase transformers of an equivalent power rating.
- Large electric motors constitute a source of substantial EMI.
- High-powered radio signals constitute a source of EMI.
- Maintain good screening of cables and cabinets.
- Consider and measure EMI fields of sites with main facility power running UNDER the floor or WITHIN the walls or ceilings of the scan room.
- Pay special attention to power substations and high-voltage power lines in proximity to the scan facility.
- If any concerns remain regarding excessive EMI fields, be sure to measure to confirm that your site meets all required specifications.

4.5 Equipment EMI "Envelopes"

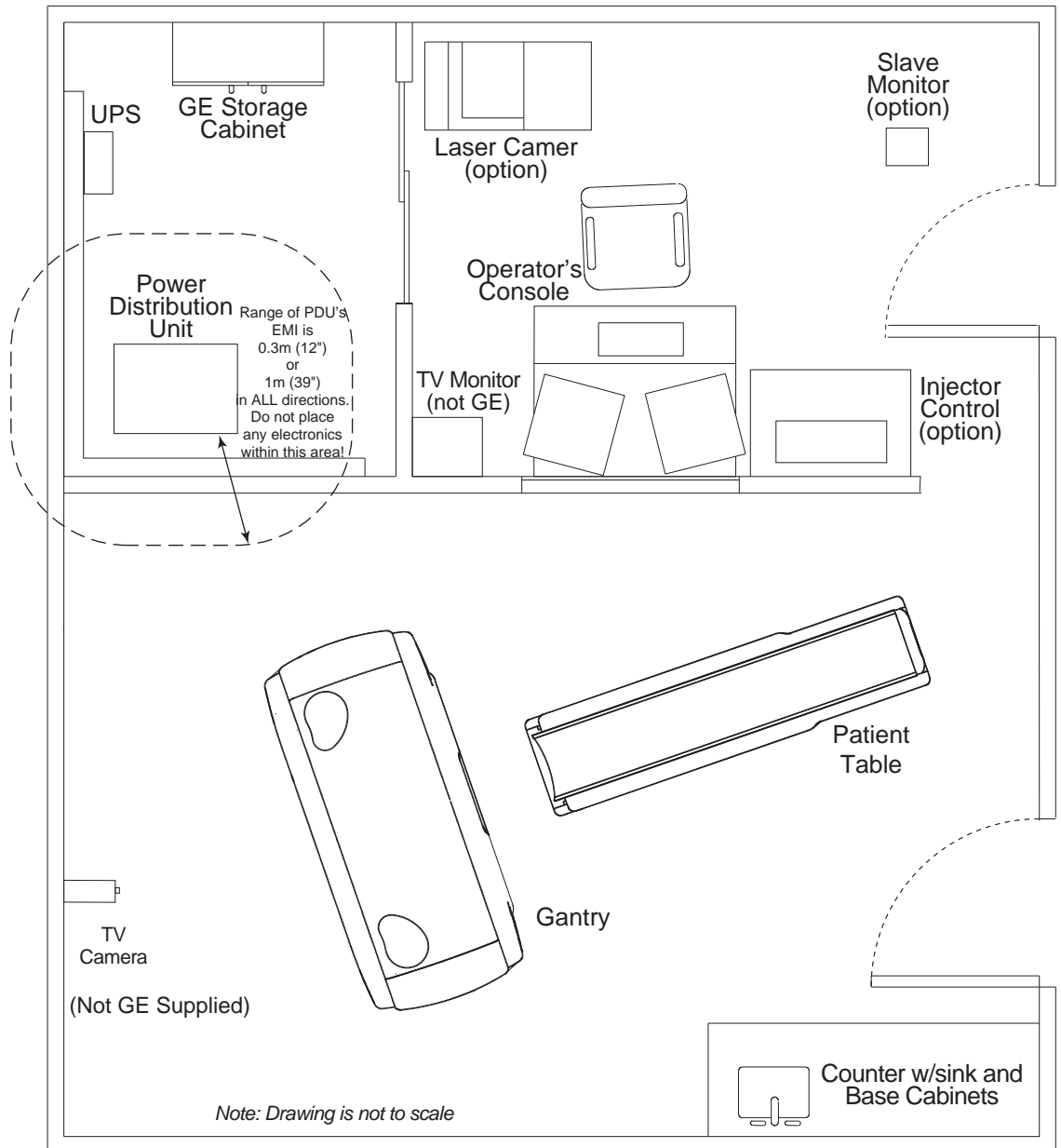

Figure 9-3 Sample Room Layout (Showing Approximate EMI Requirements)

Section 5.0: Electro-Magnetic Compatibility (EMC) (Reference IEC 60601-1-2)

5.1 General Scope

This system complies with IEC60601-1-2 Edition 2.1 (2004) EMC standard for medical devices. The system is suitable to use in the electromagnetic environment, as per the limits and recommendations described in the following tables:

- Emission Compliance level and limits (Table 9-4).
- Immunity Compliance level and recommendations to maintain equipment clinical utility (Table 9-4 and Table 9-6).

Note: This system complies with the EMC standard when used with supplied cables. If different cable lengths are required, contact a qualified GE service representative for advice.

5.2 Electromagnetic Emission (Reference IEC 60601-1-2 6.8.3.201)

The system is intended for use in the electromagnetic environment specified below. The customer or the user of the system should assure that it is used in such an environment.

Emissions Test	Compliance	Electromagnetic Environment Guidance
RF emissions CISPR 11	Group 1	The system uses RF energy only for its internal function. Therefore, its RF emissions are very low and are not likely to cause any interference in nearby electronic equipment.
RF emissions CISPR 11	Class A	When installed in such a shielded location, the system is suitable for use in all establishments other than domestic and those directly connected to the public low-voltage power supply network that supplies buildings used for domestic purposes.
Harmonic emissions IEC 61000-3-2	Not applicable	
Voltage fluctuations/ flicker emissions IEC 61000-3-3	Not applicable	

Table 9-4 Electromagnetic Emissions

5.3 Electromagnetic Immunity (Reference IEC 60601-1-2 6.8.3.201)

The system is intended for use in the electromagnetic environment specified below. The customer or the user of the system should assure that it is used in such an environment.

Immunity Test	EC 60601-1-2 Test Level	Compliance Level	Electromagnetic Environment Guidance
Electrostatic discharge (ESD) IEC 61000-4-2	± 6 kV contact ± 8 kV air	± 6 kV contact ± 8 kV air	Floors should be wood, concrete, or ceramic tile. If floors are covered with synthetic material, the relative humidity should be at least 30%.
Electrical fast transient/burst IEC 61000-4-4	± 2 kV for power supply lines ± 1 kV for input/output lines	± 2 kV for power supply lines ± 1 kV for input/output lines	Mains power quality should be a typical commercial or hospital environment
Surge IEC 61000-4-5	± 1 kV differential mode ± 2 kV common mode	± 1 kV differential mode ± 2 kV common mode	Mains power quality should be a typical commercial or hospital environment.
Voltage dips, short interruptions and voltage variations on power supply input lines IEC 61000-4-11	< 5 % U_T (> 95% dip in U_T) for 5 sec	< 5 % U_T (> 95% dip in U_T) for 5 sec	Mains power quality should be a typical commercial or hospital environment. If the user of the system requires continued operation during power mains interruptions, it is recommended that the system is powered from a partial uninterruptible power supply or a battery.
Power frequency (50/60 Hz) magnetic field IEC 61000-4-8	3 A/m	3 A/m	Power frequency magnetic fields should be at levels characteristic of a typical location in a typical commercial or hospital environment.

Table 9-5 Electromagnetic Immunity

Immunity Test	EC 60601-1-2 Test Level	Compliance Level	Electromagnetic Environment Guidance
Conducted RF IEC 61000-4-6 Radiated RF IEC 61000-4-3 (Alternative method: Full range IEC 61000-4-21 test in lieu of Large, Permanently-Installed Equipment exemption)	3 V _{RMS} 150 kHz to 80 MHz 3 V/m 150 kHz to 80 MHz	3 V 150 kHz to 80 MHz 3 V/m 150 kHz to 80 MHz	Do not use portable and mobile RF communications equipment closer to any part of the system, including cables, than the recommended separation distance calculated from the equation appropriate for the frequency of the transmitter. Recommended Separation Distance: $d = \left[\frac{3.5}{3} \right] \sqrt{P}$ (see Table 9-6) $d = \left[\frac{3.5}{3} \right] \sqrt{P}$ 80 MHz to 800 MHz (see Table 9-6) $d = \left[\frac{7}{3} \right] \sqrt{P}$ 800 MHz to 2,5 GHz (see Table 9-6) where P is the maximum output power rating of the transmitter in watts (W) according to the transmitter manufacturer and d is the recommended separation distance in meters (m). Field strengths from fixed RF transmitters, as determined by an electromagnetic site survey ^a , should be less than the compliance level in each frequency range ^b . Interference may occur in the vicinity of equipment marked with the following symbol: 

- a Field strengths from fixed transmitters, such as base stations for radio (cellular/cordless) telephones and land mobile radios, amateur radio, AM and FM radio broadcast, and TV broadcast cannot be predicted theoretically with accuracy. To assess the electromagnetic environment due to fixed RF transmitters, an electromagnetic site survey should be considered. If the measured field strength in the location in which the system is used exceeds the applicable RF compliance level above, the system should be observed to verify normal operation. If abnormal performance is observed, additional measures may be necessary, such as re-orienting or relocating the system.
- b Over the frequency range 150 kHz to 80 MHz, field strengths should be less than 3 V/m.

NOTE: These guidelines may not apply in all situations. Electromagnetic propagation is affected by absorption and reflection from structures, objects, and people.

NOTE: U_T is the AC mains voltage prior to application of the test level.

Table 9-5 Electromagnetic Immunity

The system is intended for use in an electromagnetic environment in which radiated RF disturbances are controlled. The customer or the user of the system can help prevent electromagnetic interference by maintaining a minimum distance between portable and mobile RF communications equipment (transmitters) and the system as recommended below, according to the maximum output power of the communications equipment.

Rated Maximum Output Power (P) of Transmitter Watts (W)	Separation Distance (Meters) by Frequency of Transmitter		
	150 kHz to 80 MHz $d = \left[\frac{3.5}{3}\right]\sqrt{P}$	80 MHz to 800 MHz $d = \left[\frac{3.5}{3}\right]\sqrt{P}$	800 MHz to 2.5 GHz $d = \left[\frac{7}{3}\right]\sqrt{P}$
0.01	0.12	0.12	0.23
0.1	0.37	0.37	0.74
1	1.17	1.17	2.33
10	3.69	3.69	7.38
100	11.7	11.7	23.3

For transmitters rated at a maximum output power not listed above, the separation distance can be estimated using the equation in the corresponding column, where P is the maximum output power rating of the transmitter in watts (W) according to the transmitter manufacturer.

NOTE 1: At 80 MHz and 800 MHz, the separation distance for the higher frequency range applies.

NOTE 2: These guidelines may not apply in all situations. Electromagnetic propagation is affected by absorption and reflection from structures, objects, and people.

Table 9-6 Recommended Separation Distances

As an example, keep a 1 W mobile phone (800 MHz to 2.5 GHz carrier frequency) at least 2.3 m from the system (in order to avoid image interference risks.)

LIMITATIONS MANAGEMENT: Adhering to the distance separation recommended in [Table 9-6](#), between 150 KHz and 2.5 GHz, reduces disturbances recorded at the image level, but may not eliminate all disturbances. However, when installed and operated as specified, the system maintains its essential performance by continuing to acquire, display, and store diagnostic quality images safely.

5.4 Installation Requirements and Environment Control

In order to minimize interference risks, the following requirements apply.

5.4.1 Cable Shielding and Grounding

All interconnect cables to peripheral devices must be shielded and properly grounded. Use of cables not properly shielded and grounded may result in the equipment causing radio frequency interference.

The manufacturer is not responsible for any interference caused by using other than recommended interconnect cables or panels, or by unauthorized changes or modifications to this equipment. Unauthorized changes or modifications could void the users' authority to operate the equipment.

All interconnect cables to peripheral devices must be shielded and properly grounded, except when technologically prohibited. Use of cables not properly shielded and grounded may result in the equipment causing radio frequency interference.

This Page Intentionally Blank.

Chapter 10

Radiation Protection Requirements

Section 1.0: Shielding Requirements



NOTICE Engage a **QUALIFIED RADIOLOGICAL HEALTH PHYSICIST** to review your scan room shielding requirements, taking into consideration:

- Scatter radiation levels within the scanning room (see [Figure 10-1](#)).
- Equipment placement.
- Weekly projected work-loads (number of patients/day technique (kvp*ma))
- Materials used for construction of walls, floors, ceiling, doors, and windows.
- Activities in surrounding scan room areas.
- Equipment in surrounding scan room areas (e.g., film developer, film storage)
- Room size and equipment placement within the room relative to room size.

[Figure 10-1](#) depicts measured radiation levels within the scanning room, while scanning a 32 cm CTDI phantom and using a large filter, with the technique shown. Use the mAs, kV and aperture scaling factors shown in [Table 10-1](#) to adjust exposure levels to the scan technique used at the site. *Example* (from [Figure 10-1](#)): The exposure level for a 120 kV, 800 mA, 1 sec. scan at 1270 mm (50 in.) away from the scan plane is: $10.4 \text{ mGy} \times 0.71 \times 800/100 = 59.2 \text{ mGy}$.

Note: Actual measurements can vary. Expected deviation equals $\pm 15\%$, except for the 5 mA and 1 mm techniques, where variation may be greater (up to a factor of 2), due to the inherent deviation in small values. The maximum deviation anticipated for tube output equals $\pm 40\%$.

Changed Parameter	Multiplication Factor
mAs	new mAs/100
80 kV	0.24
100 kV	0.45
120 kV	0.71
140 kV	1.00
1mm aperture	0.20
3 mm aperture	0.22
5 mm aperture	0.27
10 mm aperture	0.38
15 mm aperture	0.48
20 mm aperture	0.59
30 mm aperture	0.79
40 mm aperture	1.00

Table 10-1 Shielding Requirements Scaling



NOTICE This publication uses mGy (micrograys) to measure radiation levels. The conversion factor from mR to mGy (micrograys) is: $1 \text{ mR} = 8.69 \text{ mGy}$.

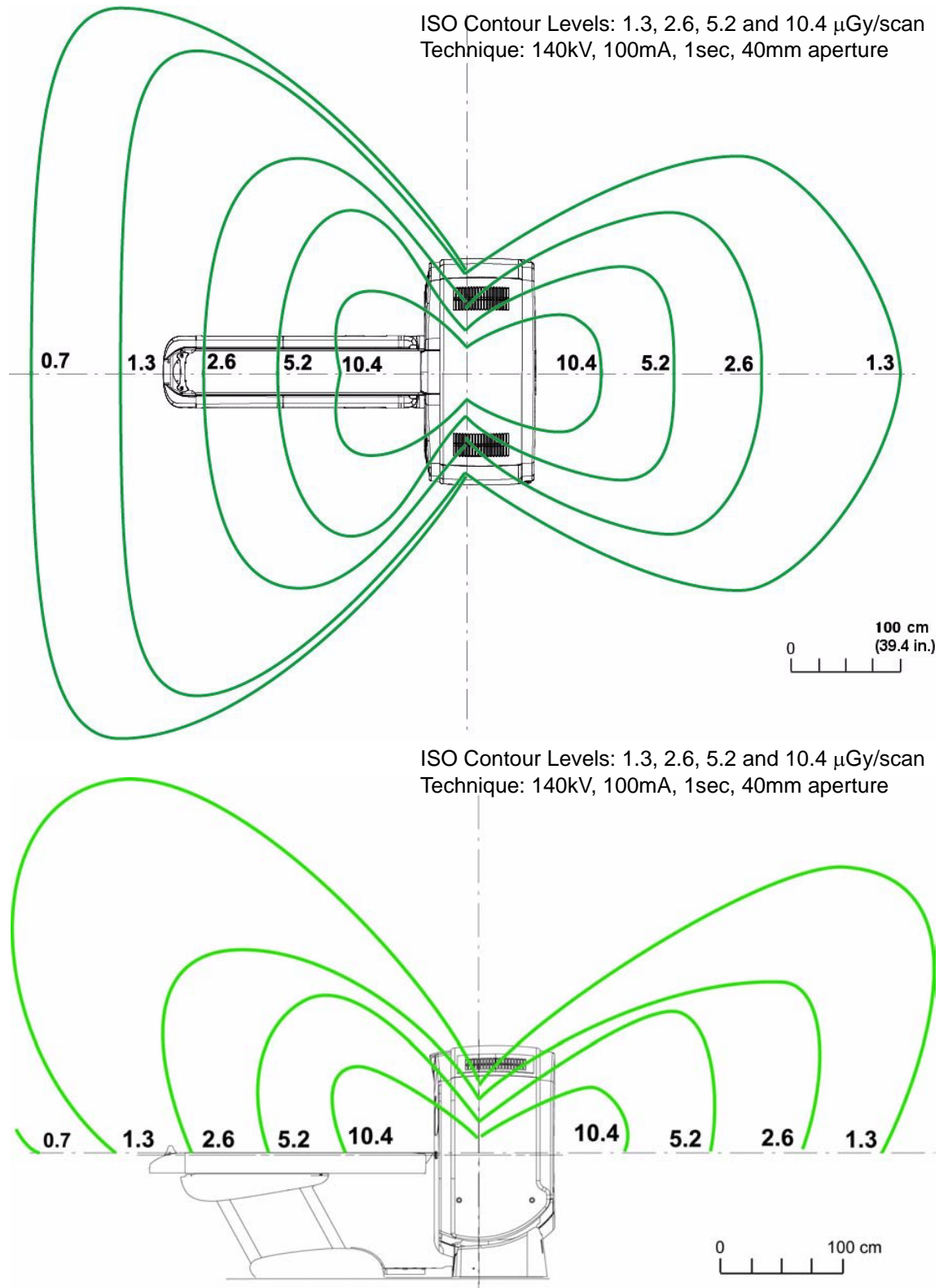

Figure 10-1 Typical Scatter Survey (Large Filter)

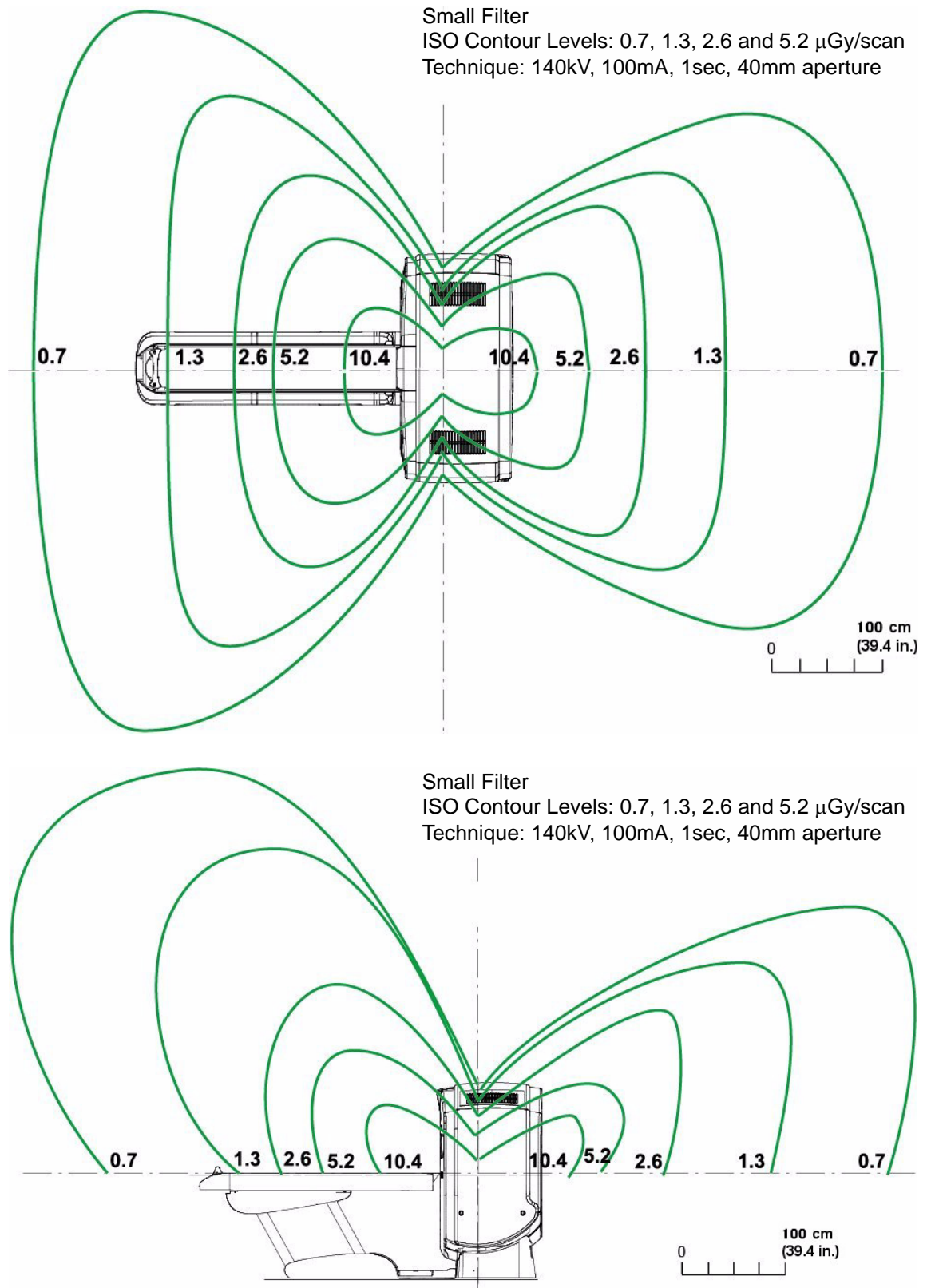

Figure 10-2 Typical Scatter Survey (Small Filter)

This Page Intentionally Blank.

Chapter 11

Network Requirements

Section 1.0: Network Connections

The network requirements listed in this chapter should allow you to connect the system to:

- Hospital/facility networks
- Filming cameras
- PACS
- Workstations
- Patient Information Systems

1.1 Network Type

Optima CT660 systems require a broadband network connection.

1.2 Network Speed

The customer and the customer's IT contact should ensure that the site provides access to broadband using one of the following interface types:

- 100BASE-TX (100 Mbit/s)
- 1000BASE-T (1000 Mbit/s [1 Gbit/s]).

1.3 Network Cable Routing

The CT system connects to the facility's network through the console. To enable proper network cabling, the customer and the customer's IT contact should:

- Provide an RJ45 wall outlet within 2 m (79 in.) of the console location.
- Provide a patch cable, not to exceed 3.05 m (10 ft), to connect the console to a wall box. (See Notes on [Figure 13-1](#))
- Complete any cable duct-work or conduit installation that the customer site-unit might require to route connecting network cables to the workstation, camera, and console.
- Ensure that the run from the hospital/facility switch to the CT wall outlet does not exceed 88 m (290 ft). Bandwidth performance degrades significantly when the length exceeds 91 m (300 ft).
- Use of STP (Shielded Twisted Pair) cable is not allowed.

Section 2.0: Customer Broadband Responsibilities

2.1 Contact GE to Find Zone Broadband Specialist

Contact your GE PMI to obtain the name of the zone broadband specialist who will:

- Work with the Customer Champion to complete any identified infrastructure changes.
- Provide IP addresses for new CT equipment.
- Provide a VPN compatible appliance that will support the IPSec tunneling protocol and 3DES data encryption.
- Utilize an Internet Service Provider that supports static routing.

2.2 Provide GE with IT Contact Information for the Site

Provide your GE PMI with an accurate site address, telephone number, contact name, and e-mail address for the customer IT contact who will:

- Coordinate VPN activities between Radiology/Cardiology and the Information Technology (IT) departments.
- Act as a focal point in assuring site broadband infrastructure meets GE Healthcare requirements for connection, as determined by a mutual assessment with the GE Healthcare connectivity team.
- Complete an equipment assessment with the GE Healthcare connectivity team to determine site readiness for broadband.

Chapter 12

Power Requirements

Be sure to communicate all necessary information in this chapter to the electrical contractor employed at the installation site.

Section 1.0: Introduction

The Power Distribution Unit (PDU) supplied with the system transforms and distributes power to all system components. The PDU constitutes the only power entry point required to operate the system. To minimize voltage regulation effects, keep power wiring between the facility main distribution panel and the PDU as short as possible.

When routing the power wiring, all three-phase wires and ground must run in the same conduit or raceway duct. Route power wires separate from the system control and signal cables, using a separate conduit or trough in a raceway duct. You may use a metallic conduit, floor duct, or surface raceway for running cables, depending upon local codes and practices. However, ensure that cable passageways are large enough to install additional cables with all other cables already installed. Do not use non-metallic conduit.

Section 2.0: System Input Power

2.1 Power Source Configuration

The system operates on a three-phase, solidly grounded four-wire wye or Delta power source. The neutral wire does not need to run to the system, (i.e., four-wire connection). If you are running a NEUTRAL wire, terminate it in the A1 box.

A dedicated feeder from the nearest Main Distribution Panel (MDP) should supply power to the system. In accordance with the National Electric Code (U.S.) and similar applicable national and local codes, the site MUST provide a protective disconnect device with LOCK-OUT and TAG-OUT provisions in the power line supplying the PDU, and MUST locate the protective disconnect device within 10 m (32 ft) of the PDU, visible to PDU service personnel. The disconnect device appears as A1 in the interconnection schematic diagrams.

2.2 Rating

The system operates on three-phase power that meets the following specifications:

For 100kVA Standard

- Voltage: 200 to 240VAC, 380 to 480 VAC
- Capacity: 100 kVA
- Frequency: 50 or 60 Hz \pm 3 Hz
- Maximum power demand = 100 kVA @ 0.85 PF at a selected technique of 140 kV, 515 mA.
- Average (continuous) power demand at maximum duty cycle = 20 kVA.
- Idle power demand (without rotation and X-ray) = 2.6 kVA.

For 75kVA Option (For Japan Only)

- Voltage: 200 to 240VAC, 380 to 480 VAC
- Capacity: 75 kVA

- Frequency: 50 or 60 Hz \pm 3 Hz
- Maximum power demand = 75 kVA @ 0.85 PF at a selected technique of 120 kV, 400 mA.
- Average (continuous) power demand at maximum duty cycle = 20 kVA.
- Idle power demand (without rotation and X-ray) = 2.6 kVA.

The A1 disconnect device referenced above must provide overcurrent protection for the system and have at least one Emergency Off switch within the scan suite, near the console. The preferred disconnect utilizes undervoltage release control, rather than shunt trip devices. The rating of the A1 disconnect device depends on the nominal line voltage at the site. Refer to [Section Section 3.0.; Recommended Power Distribution System](#) for minimum rating requirements and suggested disconnect devices.

2.3 Regulation

Total load regulation, as measured at the PDU input terminals, must not exceed 6%. The capacity of the facility transformer and size and length of feeder wires directly affect the load regulation presented to the system. Refer to [Section Section 3.0.; Recommended Power Distribution System](#), for recommended single-unit installation specifics.

2.4 Phase Imbalance

The difference between the highest line-to-line voltage and lowest line-to-line voltage must not exceed 2% of the lowest line-to-line voltage.

2.5 Sags, Surges and Transients

Sags and surges of the power line must not exceed the absolute range limits shown in [Table 12-1](#). Limit maximum transient voltages to 1500 V peak.

2.6 Grounding

The customer's electrician needs to perform the following tasks:

- Bond metal conduit, raceway, or the armor of armored cable used to power the system to the PDU cabinet and to the A1 Disconnect
- Run a dedicated 1/0 (55 mm²) or larger insulated copper ground wire from the main distribution panel to the PDU with the phase wires.
- Run the ground wire with the three-phase wires from the power source to the A1 Disconnect and from A1 Disconnect to the PDU. Grounding does not require a neutral wire.

Note: The shield or armor of armored cable ALONE does NOT provide sufficient grounding.

Bond the ground wire to the intermediate distribution panels through which it passes in accordance with local codes. The resistance between the PDU ground and the facility earth ground must not exceed 0.5 ohm. In addition, the total resistance between the PDU ground and earth must not exceed 2 ohms.

Section 3.0: Recommended Power Distribution System

In all cases, qualified personnel must verify that the transformer and feeder (at the point of take-off) and the run to the CT system meet all the requirements stated in this document.

3.1 Using a Dedicated Distribution Transformer (Recommended)

The recommended power distribution system for a CT system is a dedicated feeder from the facility main isolation transformer. The minimum recommended transformer size for a dedicated distribution transformer provided for the system is 125 kVA (100kVA standard) or 93.75kVA (75kVA option), rated 2.4% regulation at unity power factor. Table 12-2 shows the minimum recommended feeder size and overcurrent protection device based on line voltage for this configuration.

3.2 Using an Existing Distribution Transformer

If it proves necessary to power the system from an existing distribution transformer and secondary feeder, such as the equipment distribution panel of an X-ray department, avoid installation with other X-ray equipment that uses rapid film changers. These changers use a large number of high-powered, closely-spaced exposures, which may coincide with the CT scan and produce image artifacts.

3.3 System Power Requirements

Be sure that the site can meet all of the minimum power requirements listed below before installing the system:

For 100kVA Standard

- Maximum power demand = 100kVA @ 0.85 PF: at a Selected Technique of 140 kV, 515 mA.
- Continuous (average) power demand at maximum duty cycle = 20 kVA.
- Maximum allowable total source regulation is 6%.
- Minimum recommended transformer size: 125 kVA, with 2.4% rated regulation at unity power factor. Resultant maximum allowable feeder regulation is 3.6%.

Nominal line voltage MUST fall within ONE of these ranges.

Average Power [VA]	20,000	20,000	20,000	20,000	20,000	20,000	20,000	20,000	20,000
Peak Power [VA]	100,000	100,000	100,000	100,000	100,000	100,000	100,000	100,000	100,000
Nominal Line Voltage [V]	200	220	240	380	400	420	440	460	480
Hi-Line Limit, +10% [A]	220	242	264	418	440	462	484	506	528
Lo-Line Limit, -10% [A]	180	198	216	342	360	378	396	414	432
Continuous Line Current [A]	58	52	48	30	29	27	26	25	24
Momentary Line Current [A]	289	262	241	152	144	137	131	126	120
Maximum Line Current [A]	321	292	267	169	160	153	146	139	134
Minimum Recommended Circuit Breaker [A]	140	125	115	75	75	70	70	60	60
Recommended A1 disconnect panel [A]	150	150	150	90	90	90	90	90	90

Table 12-1 Nominal Line Voltage Ranges

Feeder Length (Power Substation to A1 Disconnect)	Minimum Feeder Wire Size, AWG or MCM (sq. mm)/ VAC					
	380 VAC	400 VAC	420 VAC	440 VAC	460 VAC	480 VAC
15 m (50 ft)	4 (22)	4 (22)	4 (22)	4 (22)	4 (22)	4 (22)
30 m (100 ft)	4 (22)	4 (22)	4 (22)	4 (22)	4 (22)	4 (22)
46 m (150 ft)	3 (30)	4 (22)	4 (22)	4 (22)	4 (22)	4 (22)
61 m (200 ft)	3 (30)	3 (30)	3 (30)	3 (30)	4 (22)	4 (22)
76 m (250 ft)	1 (45)	2 (35)	2 (35)	3 (30)	3 (30)	3 (30)
91 m (300 ft)	1 (45)	1 (45)	1 (45)	2 (35)	2 (35)	3 (30)
107 m (350 ft)	1/0 (55)	1/0 (55)	1 (45)	1 (45)	1 (45)	2 (35)
122 m (400 ft)	2/0 (70)	1/0 (55)	1/0 (55)	1 (45)	1 (45)	1 (45)

Table 12-2 Minimum Feeder Wire Size

Feeder Length (Power Substation to A1 Disconnect)	Minimum Feeder Wire Size, AWG or MCM (sq. mm)/ VAC		
	200 VAC	220 VAC	240 VAC
15 m (50 ft)	2 (35)	3 (30)	3 (30)
30 m (100 ft)	2/0 (70)	1/0 (55)	1/0 (55)
46 m (150 ft)	5/0 (125)	3/0 (85)	3/0 (85)
61 m (200 ft)	6/0 (170)	5/0 (125)	4/0 (100)
76 m (250 ft)	6/0 (170)	6/0 (170)	5/0 (125)
91 m (300 ft)	7/0 (215)	6/0 (170)	6/0 (170)
107 m (350 ft)	8/0 (275)	7/0 (215)	6/0 (170)
122 m (400 ft)	8/0 (275)	8/0 (275)	8/0 (275)

Table 12-3 Minimum Feeder Wire Size

Note: In all cases the recommended ground wire is a 55 sq. mm (1/0) ground wire.

Sub-feeder Length (A1 to PDU)	Minimum Sub-feeder Wire, AWG or MCM (sq. mm)					
	380 VAC	400 VAC	420 VAC	440 VAC	460 VAC	480 VAC
9.7536 m (32 ft)	1/0 (55)	1/0 (55)	1 (45)	1 (45)	2 (35)	2 (35)

Table 12-4 Minimum Sub-Feeder Wire Size

Sub-feeder Length (A1 to PDU)	Minimum Sub-feeder Wire, AWG or MCM (sq. mm)		
	200 VAC	220 VAC	240 VAC
9.7536 m (32 ft)	1/0 (55)	1/0 (55)	1/0 (55)

Table 12-5 Minimum Sub-Feeder Wire Size

For 75kVA Option

- Maximum power demand = 75kVA @ 0.85 PF: at a Selected Technique of 120 kV, 400 mA.
- Continuous (average) power demand at maximum duty cycle = 20 kVA.
- Maximum allowable total source regulation is 6%.
- Minimum recommended transformer size: 93.75 kVA, with 2.4% rated regulation at unity power factor. Resultant maximum allowable feeder regulation is 3.6%.

Nominal line voltage MUST fall within ONE of these ranges.

Average Power [VA]	20,000	20,000	20,000	20,000	20,000	20,000	20,000	20,000	20,000
Peak Power [VA]	75,000	75,000	75,000	75,000	75,000	75,000	75,000	75,000	75,000
Nominal Line Voltage [V]	200	220	240	380	400	420	440	460	480
Hi-Line Limit, +10% [A]	220	242	264	418	440	462	484	506	528
Lo-Line Limit, -10% [A]	180	198	216	342	360	378	396	414	432
Continuous Line Current [A]	58	52	48	30	29	27	26	25	24
Momentary Line Current [A]	217	197	180	114	108	103	98	94	90
Maximum Line Current [A]	241	919	200	127	120	115	109	105	100
Minimum Recommended Circuit Breaker [A]	110	100	100	70	70	65	65	60	60
Recommended A1 disconnect panel [A]	125	125	125	90	90	90	90	90	90

Table 12-6 Nominal Line Voltage Ranges

Feeder Length (Power Substation to A1 Disconnect)	Minimum Feeder Wire Size, AWG or MCM (sq. mm)/ VAC					
	380 VAC	400 VAC	420 VAC	440 VAC	460 VAC	480 VAC
15 m (50 ft)	4 (22)	4 (22)	4 (22)	4 (22)	4 (22)	4 (22)
30 m (100 ft)	4 (22)	4 (22)	4 (22)	4 (22)	4 (22)	4 (22)
46 m (150 ft)	4 (22)	4 (22)	4 (22)	4 (22)	4 (22)	4 (22)
61 m (200 ft)	3 (30)	4 (22)	4 (22)	4 (22)	4 (22)	4 (22)
76 m (250 ft)	3 (30)	3 (30)	3 (30)	4 (22)	4 (22)	4 (22)
91 m (300 ft)	1 (45)	2 (35)	3 (30)	3 (30)	3 (30)	3 (30)
107 m (350 ft)	1 (45)	1 (45)	2 (35)	2 (35)	3 (30)	3 (30)
122 m (400 ft)	1/0 (55)	1 (45)	1 (45)	1 (45)	1 (45)	3 (30)

Table 12-7 Minimum Feeder Wire Size

Feeder Length (Power Substation to A1 Disconnect)	Minimum Feeder Wire Size, AWG or MCM (sq. mm)/ VAC		
	200 VAC	220 VAC	240 VAC
15 m (50 ft)	3 (30)	3 (30)	4 (22)
30 m (100 ft)	1/0 (55)	1 (45)	1 (45)
46 m (150 ft)	3/0 (85)	2/0 (70)	2/0 (70)
61 m (200 ft)	5/0 (125)	4/0 (100)	3/0 (85)

Table 12-8 Minimum Feeder Wire Size

Feeder Length (Power Substation to A1 Disconnect)	Minimum Feeder Wire Size, AWG or MCM (sq. mm)/ VAC		
	200 VAC	220 VAC	240 VAC
76 m (250 ft)	6/0 (170)	5/0 (125)	4/0 (100)
91 m (300 ft)	6/0 (170)	5/0 (125)	5/0 (125)
107 m (350 ft)	7/0 (215)	6/0 (170)	5/0 (125)
122 m (400 ft)	7/0 (215)	6/0 (170)	6/0 (170)

Table 12-8 Minimum Feeder Wire Size

Sub-feeder Length (A1 to PDU)	Minimum Sub-feeder Wire, AWG or MCM (sq. mm)					
	380 VAC	400 VAC	420 VAC	440 VAC	460 VAC	480 VAC
9.7536 m (32 ft)	4 (22)	4 (22)	4 (22)	4 (22)	4 (22)	4 (22)

Table 12-9 Minimum Sub-Feeder Wire Size

Sub-feeder Length (A1 to PDU)	Minimum Sub-feeder Wire, AWG or MCM (sq. mm)		
	200 VAC	220 VAC	240 VAC
9.7536 m (32 ft)	2 (35)	2 (35)	2 (35)

Table 12-10 Minimum Sub-Feeder Wire Size

Note: Note: In all cases the recommended ground wire is a 55 sq. mm (1/0) ground wire. The information in [Table 12-1](#), [Table 12-2](#), and [Table 12-4](#) (above) assumes the use of copper wire, rated 75 C and run in steel conduit. All ampacity is determined in accordance with the National Electrical Code (NFPA 70), Table 310-16 (2002). The ampacity of the circuit protection device listed above determines the minimum feeder size, except where total source regulation limits require a larger size.



NOTICE Power feeders running under the scan room floor, as well as power vault substations under the floor, above the scan suite, or in adjacent rooms, may cause excessive EMI fields. The responsibility for meeting all site EMI requirements rests with the customer.

Chapter 13

Interconnection Data

Section 1.0: Introduction

The customer and the customer’s electrical contractor should refer to the information in this section when establishing network and power interconnections for the system. Please note the following:

- [Figure 13-1](#) shows interconnection runs for a 50/60 Hz system.
- [Table 13-1](#) shows component designators for supplied equipment and options and wall power outlets.
- [Table 13-7](#) lists customer-installed wiring and supplied cables. The actual length of each run is less than the length of supplied cables to allow for routing inside the equipment. Cable diameters and sizes of connectors are provided to aid in sizing conduit and access plates.
- [Table 13-2](#) lists details for connection to the system and GE approved accessories using standard (short) length and non-standard (long) length cables, respectively. Details appear for the following types of runs, when appropriate:
 - Flush-floor duct
 - Computer floor
 - Through-wall bushing
 - Junction box
 - Surface floor duct
 - Through-floor duct
 - Wall duct
 - Conduit
- To minimize the need for additional junction boxes, use either a cable raceway system or a raised computer floor. Optima CT660 systems use prefabricated cables with large plugs. Therefore, try to avoid conduit or pipe for cable runs.

Section 2.0: Component Designators

DESIGNATOR	APPLIES TO	SOURCE
A1	Primary power disconnect	Contractor supplied
CT1	Patient table	System
CT2	Gantry	System
OC1	console/computer	System
PDU	Power Distribution Unit	System
SEO	System emergency off	Contractor supplied
SM	Slave monitor	Option
WL	“X-ray on” warning light	Contractor supplied
DS	Door Interlock Switch	Contractor supplied
BBNC	Broad-band network connection	Contractor supplied

Table 13-1 Component Designators

Section 3.0: Interconnect Runs, Wiring and Cables

3.1 GE Healthcare Supplied (Standard Length 5371684) (Reference IEC 60601-1-2 6.8.3.201)

Run #	Length, Actual (Usable)		Part #	Description	UL Cable Information							Pull Size mm (Inches)	
	ft	m			UL Style	Flam. Rating	Voltage Rating	Voltage Actual	Temp. Rating (C)	Dia. mm (inch)	# of Cond		Size AWG
050	28 (20)	9 (6)	2343529-2	HVDC, PDU to Gantry	2587	FT4	600	+ & - 350VDC	90	19 0(.751)	3	(2) 4 (1) 8	22 (0.87) Dia
051	28 (20)	9 (6)	2343530-2	HVAC, PDU to Gantry	2587	FT4	600	440Y/254	90	15 (0.604)	4	14	11 (0.44) Dia
052	28 (20)	9 (6)	2343528-2	LVAC, PDU to Gantry	2587	FT4	600	120/208Y	90	14 0(.542)	5	8	56 (2.22) Dia
053	65 (60)	20 (18)	2343531-2	LVAC, PDU to Console	2587	FT4	600	120VAC	90	12 (0.483)	3	10	56 (2.22) Dia
054			n/a	LVAC, Gantry to Table	1015		600	120VAC			3	14	
055	28 (20)	9 (6)	2371450-2	Ground, PDU to Raceway	1284	VW-1 (FT-1)	600	0	105	16 0(.608)	1	1/0	16 (0.62) Dia
056	69 (56)	21 (17)	2371450-4	Ground, Raceway to Console	1283	VW-1 (FT-1)	600	0	105	12 (0.467)	1	2	12 (0.48) Dia
100	32.5 (20)	10 (6)	5120646-2	Signal, Gantry TGPU to PDU		FT-4	300	<30VDC	80	11 (0.440)	25	22	17 x 58 (0.68 x 2.30) 19 x 51 (0.75 x 2.01)
101	71 (60)	22 (18)	5120645-2	Signal, Gantry TGPU to OC		FT-4	300	<30VDC	80	11 (0.440)	25	22	17 x 58 (0.68 x 2.30) 19 x 51 (0.75 x 2.01)
102	68 (60)	22 (18)	2373436-3	Signal (LAN), Gantry to OC			1900	<30VDC		6 (0.234)	8	24	15 (0.59) Dia
103	65 (60)	20 (18)	5125259-2	Fiber Optic, Gantry to OC			N/A	N/A			1	N/A	10 (0.39) Dia
104			n/a	Signal, Gantry to Table		FT-4	300		80	6 (0.234)	25	22	

Table 13-2 GE Healthcare Supplied Cables (Standard Run) - UL Information

3.2 GE Healthcare-Supplied (Optional, Long Run Length 5371684-2) (Reference IEC 60601-1-2 6.8.3.201)

Run #	Length, Actual (Usable)		Part #	Description	UL Cable Information								Pull Size mm (Inches)
	ft	m			UL Style	Flam. Rating	Voltage Rating	Voltage Actual	Temp. Rating (C)	Dia. mm (inch)	# of Cond	Size AWG	
050	62 (56)	19 (17)	2343529	HVDC, PDU to Gantry	2587	FT4	600	+ & - 350VDC	90	19 0(.751)	3	(2) 4 (1) 8	22 (0.87) Dia
051	62 (56)	19 (17)	2343530	HVAC, PDU to Gantry	2587	FT4	600	440Y/254	90	15 (0.604)	4	14	11 (0.44) Dia
052	62 (53)	19 (16)	2343528	LVAC, PDU to Gantry	2587	FT4	600	120/208Y	90	14 0(.542)	5	8	56 (2.22) Dia
053	82 (76)	25 (23)	2343531	LVAC, PDU to Console	2587	FT4	600	120VAC	90	12 (0.483)	3	10	56 (2.22) Dia
054	-	-	n/a	LVAC, Gantry to Table	1015		600	120VAC			3	14	
055	62 (53)	19 (16)	2371450	Ground, PDU to Raceway	1284	VW-1 (FT-1)	600	0	105	16 0(.608)	1	1/0	16 (0.62) Dia
056	86 (72)	26 (22)	2371450-3	Ground, Raceway to Console	1283	VW-1 (FT-1)	600	0	105	12 (0.467)	1	2	12 (0.48) Dia
100	69 (56)	21 (17)	5120646	Signal, Gantry TGPU to PDU		FT-4	300	<30VDC	80	11 (0.440)	25	22	17 x 58 (0.68 x 2.30) 19 x 51 (0.75 x 2.01)
101	85 (72)	26 (22)	5120645	Signal, Gantry TGPU to OC		FT-4	300	<30VDC	80	11 (0.440)	25	22	17 x 58 (0.68 x 2.30) 19 x 51 (0.75 x 2.01)
102	85 (72)	26 (22)	2373436-2	Signal (LAN), Gantry to OC			1900	<30VDC		6 (0.234)	8	24	15 (0.59) Dia
103	85 (76)	25 (23)	5125259	Fiber Optic, Gantry to OC			N/A	N/A			1	N/A	10 (0.39) Dia
104	-	-	n/a	Signal, Gantry to Table		FT-4	300		80	6 (0.234)	25	22	

Table 13-3 GE Healthcare Supplied Cables (Option Run) - UL Information

13 - Interconnection Data

3.3 GE Healthcare Supplied (Cables of Options) (Reference IEC 60601-1-2 6.8.3.201)

OPTION	LENGTH, ACTUAL (USABLE)		PART #	DESCRIPTION	UL CABLE INFORMATION								PULL SIZE MM (INCHES)
	ft	m			UL Style	Flam. Rating	Voltage Rating	Voltage Actual	Temp. Rating (C)	Dia. mm (inch)	# of Cond	Size AWG	
Injector	100	30.5	5169456	GANTRY TO INJECTOR	1007	VW-1	300	<30VDC	80	1.57 (0.062)	3	22	45(1.78) Dia
	8.2	2.5	5317258	POWER CABLE INJECTOR TO CONSOLE	62	VW-1	300	120VAC	60	9.4 (0.37)	3	14	36(1.41) Dia
Cardiac	30	9.1	5198566	GANTRY TO EKG MONITOR	2919	UL1685 UL loading	30	<30VDC	80	6.45 (0.254)	6	24	37(1.45) Dia
Adv 4D Resp	100	30.5	5199717	GANTRY TO RPM UNIT	2464	FT4	300	<30VDC	80	6.6 (0.26)	4	22	37(1.45) Dia

Table 13-4 GEMS Supplied Cables for Options - UL Information

3.4 UPS Wiring Cables (Reference IEC 60601-1-2 6.8.3.201)

Run #	Length Actual (Usable)		Part #	Description	UL Cable Information								Pull Size mm (inches)
	ft	m			UL Style	Fiam. Rating	Voltage Rating	Voltage Actual	Temp. Rating (C)	Dia. mm (inch)	# of Cond	Size AWG	
060	19 (15)	4.6	2391751	POWER CABLE, NGPDU TO UPS	2587	FT4	600	208VAC	90	5.8 (0.228)	5	8	
061	19 (15)	4.6	2391751-3	POWER CABLE, UPS DISCONNECT PANEL TO NGPDU	2587	FT4	600	208VAC	90	5.8 (0.228)	4	8	
110	45 (40)	13.6	5169224	UPS CONTROL CABLE	2587	FT4	600	120VAC	90	10.3 (0.406)	5	18	

Table 13-5 UPS Wiring Cables

3.5 A1 UPS

PDU Type & Model No.	Maximum Mom. kVA Rating	Required Main Disconnect (A1) Catalog No.		Optional Partial UPS Kit Catalog No.
		Europe & Asia (380-400V or 420V)	North America (440V or 460-480V)	
NGPDU-80 2326492-80	100kVA	E4502AC (110A) (incl. Auto Restart & Integrated UPS Control)	E4502AB (90A) (incl. Auto Restart & Integrated UPS Control)	B7999ZA (incl. 12.5KVA UPS&40A hardware kit) REQUIRES one of the A1 Panels shown at left

Table 13-6 A1 UPS

3.6 Contractor/Customer-Supplied

Customer Installed Wiring		Description	Cables Supplied			Plug Pulling Dimensions		Wire and Cable Pigtails ft. (M.)	
Qty	Size AWG (MM ²)		Part No	LENGTH ft. (M.)	DIA. in (mm)	From	TO	From	To
RUN NO. 1 FROM PRIMARY POWER SOURCE TO FACILITY DISCONNECT (POWER SOURCE - A1)									
Maximum Run Length *									
3	*	POWER						3 (1)	3(1)
1	1/0 (50)	GROUND						3 (1)	3 (1)
RUN NO. 2 FROM FACILITY DISCONNECT TO POWER DISTRIBUTION UNIT (A1 - PM)									
3	*	POWER						3 (1)	3(1)
1	1/0 (50)	GROUND						3 (1)	3 (1)
-	-	NEUTRAL -- Not Required						3 (1)	3 (1)
RUN NO. 3 FROM FACILITY DISCONNECT TO SYSTEM EMERGENCY OFF (A1 - SEO)									
2	14 (2)	POWER						6 (2)	6 (2)
1	14 (2)	GROUND						6 (2)	6 (2)
RUN NO. 4 POWER DISTRIBUTION UNIT TO WARNING LIGHT CONTROL (PDU - WL)									
2	14 (2)	WARNING LIGHT 24 VOLT CONTROL TS6 1, 2, 3, 4, 5, 6, 7, 8							
RUN NO. 5 POWER DISTRIBUTION UNIT TO SCAN ROOM DOOR INTERLOCK (PDU - DOOR SWITCH)									
2	14 (2)	SCAN ROOM DOOR INTER LOCK TS6 9, 10							
*	REFER TO Table 12-4 and Table 12-5 on page 108 FOR AWG (MM2) WIRE SIZES								
RUN NO. n/a BBNC									
1	customer determined	Hospital Broadband Network Connection (Wall Jack: Placed on the wall behind the console.)							

Table 13-7 Runs 1, 2, 3, 4 and 5 Connections

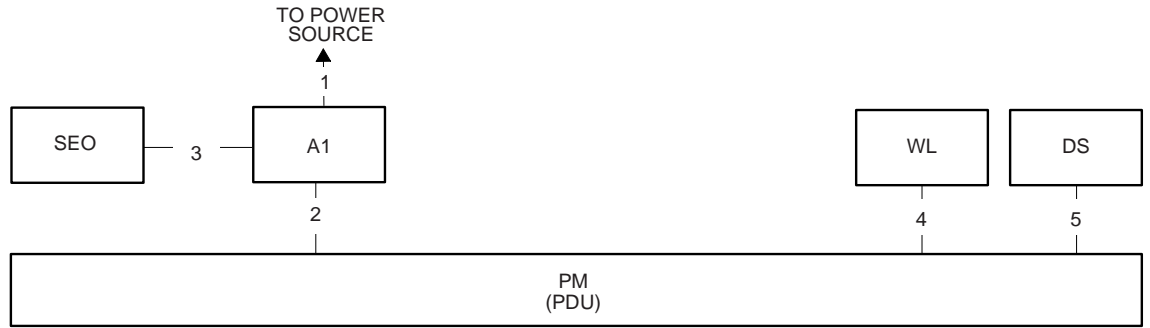

NOTES:

- 1) Used for remote diagnostics - Option
- 2) Refer to the appropriate Pre-installation / Installation documents for the Laser Camera
- 3) Category 5 cable. Use one of the following patch cords:

CAT Num	GE Part Num	Length
K9000WB	2215028-10	20 m
K9000KP	2215028-5	10 m
K9000JR	2215028-4	5 m
K9000WA	2215028-9	3 m

- 4) In order to avoid any violation of each National Regulation (NEC in USA, CCC in China, etc.), use of the compliant cable/wire is recommended. For China market, China end-user shall purchase the power supply cable that has the CCC mark.

Only one phone connection is required for the system.

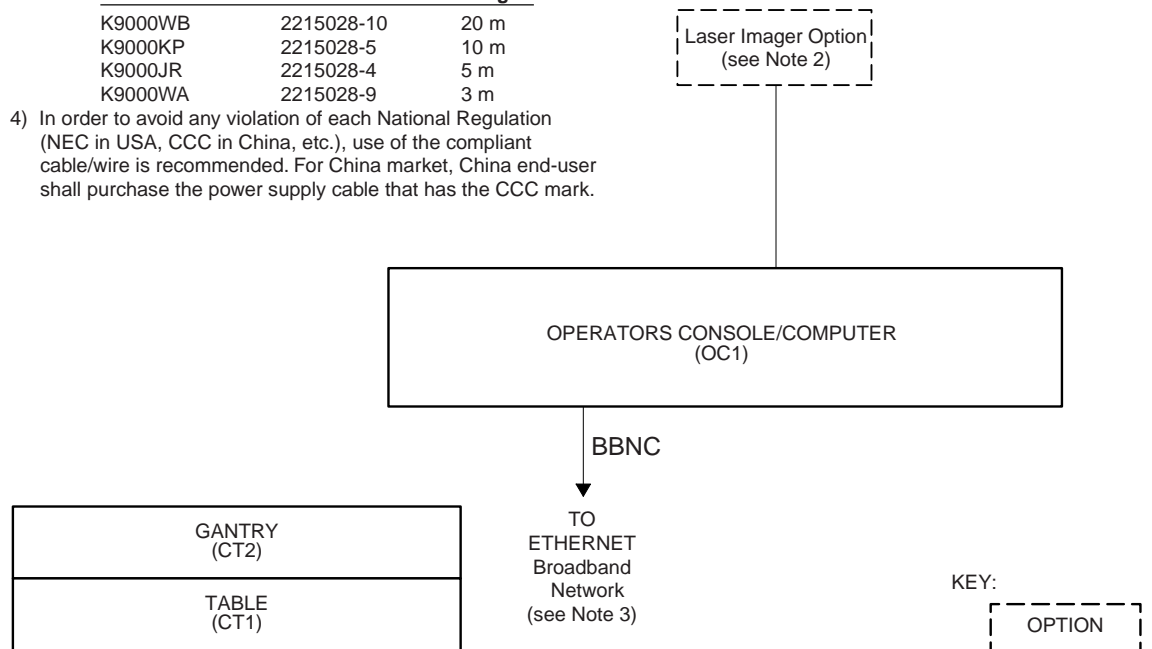

KEY:

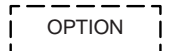

Figure 13-1 Interconnection Runs

3.7 Fuse

ITEM	NUMBER	QTY	FRU	DESCRIPTION/NAME
1	5365852	2	Y	NGPDU-80 Input Fuse (160A 690VAC)
2	2364059	1	Y	GLASS FUSE (6.3A 250V)
3	46-170021P50	1	Y	FUSE 12 AMPS 250 VOLTS BUSSMAN MDA12 DUAL ELEMENT.
4	46-170021P15	1	Y	FUSE 8 AMPS 250 VOLTS REVIEWED TK, 7 91.
5	2336517-2	2	Y	FUSE 25 AMPS 700 VOLTS 2.5M SECONDS
6	46-170021P31	2	Y	One-HalfA, 250V SLO-BLO FUSE. TYPE 3AG, 1.25aprox. X 0.25aprox. GLASS BODY. REVIEWED TK, 7-91.
7	2379651	1	Y	FUSE - 700 V, 200 A, FAST SEMI
8	5327449	2	Y	PROTECTION FUSE, 3.2A, NA, FAST ACTION, 250V, HM FUSE 3.2A
9	5327448-2	1	Y	PROTECTION FUSE, 2A, NA, FAST ACTION, 250V, HM FUSE
10	5327448	2	Y	PROTECTION FUSE, 1A, NA, FAST ACTION, 250V, HM FUSE
11	2142415-9	1	Y	PROTECTION FUSE, 25A, TIME DELAY, 600VAC 250VDC, CHASSIS MOUNTED
12	2148403-3	1	Y	PROTECTION FUSE, 2A, FAST ACTION, 250V, 5X20MM
13	2142415-4	1	Y	PROTECTION FUSE, 5A, TIME DELAY, 600VAC 250VDC, BOARDS USE FUSE CLIPS
14	2142415-7	1	Y	PROTECTION FUSE, 15A, TIME DELAY, 600VAC 250VDC, BOARDS USE FUSE CLIPS
15	2142415-5	1	Y	PROTECTION FUSE, 8A, TIME DELAY, 600VAC 250VDC, BOARDS USE FUSE CLIPS
16	5118644	1	Y	FAST ACTION 15 AMPS 250 VOLTS 0.01 SECONDS U0028FF

Table 13-8 FUSE KIT Optima CT660 (5371451-2 BOM, rev x)

Section 4.0: Contractor Supplied Components

REFERENCE	ASSOCIATED EQUIPMENT	MATERIAL/LABOR SUPPLIED BY CUSTOMER CONTRACTOR	USA VENDOR / CAT NO. GE CATALOG
A1 380 - 480V 50/60 Hz	Fusible Disconnect and Magnetic Contactor	3 Pole, 380V - 480V, Combination breaker with magnetic contactor. Includes control transformer, optional UPS interface, On/Off controls and auto-restart feature.	Recommend*: <ul style="list-style-type: none"> E4502AC (110A) E4502AB (90A)
BBNC (required)	Broad-Band Network Connection System Components	Broad-Band network connection wall jack, located within 1m (39inches) of Operator Console location, for internal hospital networking and InSite Broad-Band connectivity. Cabling to conform to facility's IT standards. Reference the system installation drawings supplied by Installation Support Services within your geographic area.	

*Refer to [Table 13-6 on page 115](#)

Table 13-9 Contractor-Supplied Components

Section 5.0: Scan Room Warning Light and Door Interlock

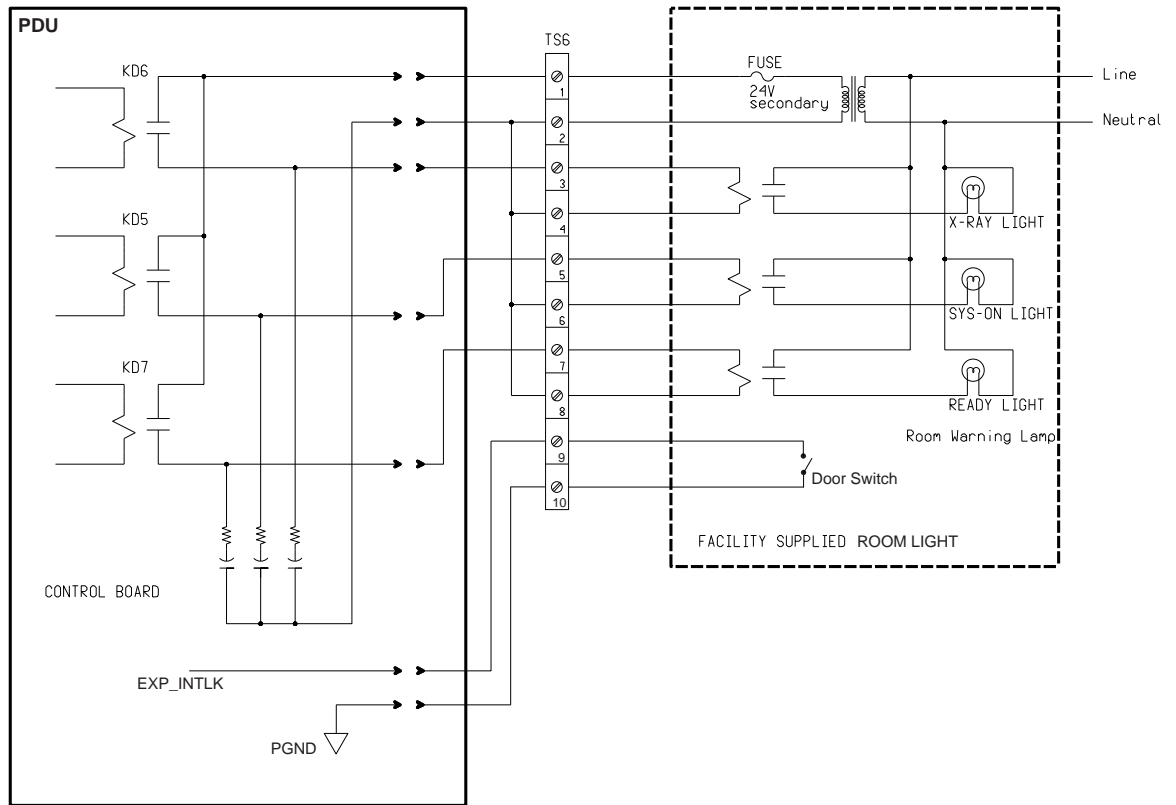
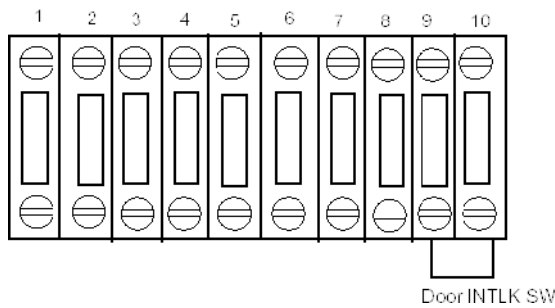
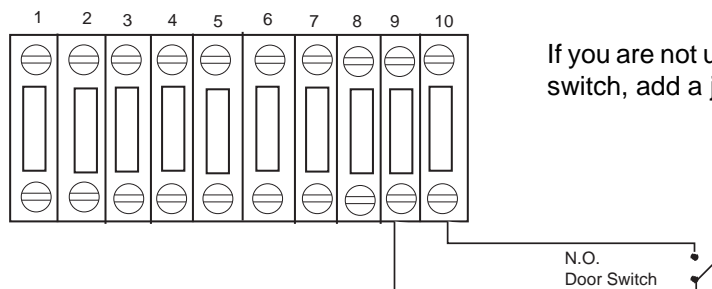

Figure 13-2 TS6 X-Ray Warning Light Connections



Without the jumper in place, exposures do not occur. Check this jumper if you get scan interlock errors.

Figure 13-3 TS6 Room Door Interlock Connections - Without a Door Interlock



If you are not using a door switch, add a jumper.

Figure 13-4 TS6 Room Door Interlock Connections - With a Door Interlock

Chapter 14

Delivery and Storage Requirements

This chapter provides information necessary for planning a safe and successful delivery of the system from GE Healthcare to the receiving area of the installation site, and from the receiving area of that facility to the scan suite.

Section 1.0: Delivery to the Facility

Your Project Manager of Installation will determine the most appropriate means of transporting the system to your facility. However, the type of receiving area at the facility where the installation will occur determines, to a large extent, the method used to transport the system to that facility. When planning for delivery, facilities fall into two general categories: those with a loading dock, and those without a loading dock.

1.1 Loading Dock Deliveries

Facilities with a loading dock in their receiving area can generally accommodate delivery of the system by van. This is the preferred method of transporting the system to the installation site, as dock-to-dock shipment by van minimizes the possibility of dropping the gantry. Also, packing the CT system for van shipment involves minimum tear-down of components. This system is shipped Lean packed on pallets and dollies with approximately 10 units.

1.2 Ground (Non-Loading Dock) Deliveries

Facilities without a loading dock usually require ground delivery by either liftgate or tiltbed truck. Such deliveries require unloading the system components from the truck and then rolling them across smooth sidewalks or other paved surfaces into the facility.

1.2.1 Liftgate Truck

Delivery of the system by liftgate truck requires an appropriate capacity truck with a liftgate capable of lifting 3 tons. If using a rollback truck, the Project Manager of Installation should be on-site at the time of delivery to supervise this operation in person.

1.2.2 Tiltbed Truck

Delivery of the system by tiltbed truck also requires an appropriate capacity truck, capable of lifting 3 tons. Safe transport of the system by tiltbed truck requires securing the components to the truck to prevent damage during transportation. To avoid damage to the gantry or dolly when removing the gantry from a tiltbed truck, the Project Manager of Installation should direct the driver to attach straps to the lowest possible point on the dolly and lower the gantry at the slowest reasonable rate.

1.2.3 Forklift Truck

A forklift can be used to unload the gantry, provided that the lifting option is ordered and delivered. The system will arrive with a lifting skid attached to the gantry and table. This option cannot be added later as an on-site addition.

Section 2.0: Delivery to the Scan Suite

Once at the installation site, conveyance of the system into the scan suite may involve special considerations, such as vertical lifting, or transportation through stairwells, which involves additional planning by the Project Manager of Installation.

2.1 Lifting

Both vertical and horizontal lifting require professional riggers. The PMI should always notify CT engineering before attempting either lifting procedure and should make sure that the order includes the necessary lifting fixtures, as both vertical and horizontal fixtures must appear on the order for them to ship with the system.

If delivery requires vertical lifting, the PMI adds the appropriate identifier to the order. The gantry ships in a vertical lifting crate with lifting instructions for riggers.

If delivery requires horizontal lifting, the PMI adds the corresponding identifier to the order. The gantry ships in a horizontal lifting crate with lifting instructions for riggers.

2.1.1 Stairway Deliveries

Stairways with angles at or less than 45 degrees can accommodate delivery of system components. If the site requires delivery through stairwells, the PMI adds the appropriate identifier to the order to ensure proper packaging of the system, and notifies CT engineering before attempting the procedure. The components ship attached to special lifting skids with lifting instruction for riggers.

2.2 Floor Protection

GE recommends floor protection along the delivery path from the dock/receiving area to scan room.

2.3 Un-loading and un-packing the System

Retain the packaging surrounding the following components:

- Console-Shipped on a shock resistant skid. Do not remove the skid.
- UPS-Shipped on a shock resistant skid. Do not remove the skid.

Section 3.0: Dollies

3.1 Installations within the United States

Typically, domestic shipments (shipments within the United States) involve the use of dollies for moving the gantry, table, and console. After completing installation, return the dollies to GE using the shipping document found in Box #1.

3.2 Zero Clearance Dollies

Deliveries involving small elevators with a depth of at least 2692 mm (106 in.) require zero clearance dollies. Zero clearance dollies allow movement of the gantry in tight areas; avoid using them for normal dock or van deliveries. To order zero clearance dollies, go to: <http://www.umi-dollyshop.com>.

3.3 Tilting Table Dollies

Deliveries involving small elevators with a depth of at least 2438 mm (96 in.) require tilting table dollies. If storing the system prior to installation, do not order tilt dollies. If you are unable to obtain tilt dollies for delivery, substitute riggers in their place. A limited number of tilt dollies exist for U.S. deliveries. To order tilt dollies, go to: <http://www.umi-dollyshop.com>.

3.4 Installations Outside of the United States

Customers may purchase dollies (B7850LD) for shipments outside of the United States. After removing the system from the crates, DO NOT return dollies shipped outside of the US to GE Healthcare in Milwaukee, WI, USA. Instead, forward them to the local GE office or warehouse. Zero Clearance and Tilting Table dollies can be purchased through UMI, To buy tilt dollies, go to: <http://www.umi-dollyshop.com>.

Section 4.0: Gantry Delivery Considerations

4.1 Gantry Shipping State

The gantry ships with most covers installed, and the assembly mounted between two dollies (see [Figure 14-1](#)). Two side rails, bolted to the dollies, stabilize the dollies and protect the gantry. Use the dolly elevating casters to lift the gantry off its base and roll it into position.



Figure 14-1 Gantry with Shipping Dollies and Side Rails

4.2 Door Openings

Unobstructed door openings, for moving equipment into the building, must measure 1067 mm X 2083 mm (42 in. X 82 in.) minimum. Corridors with a width of 2439 mm (8 ft.) also prove helpful.

4.3 Elevator Requirements

When moving the gantry from the receiving location to the scanning room, pay special attention to elevator size and capacity. Removing side rails and one dolly after placing the gantry in the elevator reduces the gantry width/length and elevator depth requirements.

Due to gantry component weight differences all weights listed below are averages. This change can measure ± 18.14 kg (± 40 lb). Contact the elevator manufacturer if the gantry weight exceeds elevator capacity (see [Table 14-1](#)).

Configuration	Length	Width	Height	Weight
Dollies On, Side Rails On	2810 mm (111 in.)	1290 mm (51 in.)	2000 mm (79 in.)	2050 kg (4520 lb)
Dollies On, Side Rails Removed	2810 mm (111 in.)	1000 mm (39.4 in.)	2000 mm (79 in.)	2022 kg (4458 lb)
Dollies Off, Covers Off	1970 mm (77 in.)	860 mm (34 in.)	1850 mm (73 in.)	1671 kg (3684 lb)

Table 14-1 Size of Gantry & Dollies, with and without Side Rails

The minimum hallway and door size for a gantry with covers and dollies attached but side rails removed, is 1016 mm (40 in.). For alternative lifting arrangements and instructions, contact GE Installation Support Services.

Section 5.0: Table Delivery Considerations

Table Delivery Considerations

GT1700V:

The table is shipped without side covers installed. Covers are shipped in separate boxes. The table is mounted with two dollies.

Lite Table:

The whole Lite table is shipped in one box. The side and base covers are disassembled and put on the table. The table is mounted between two dollies.

For the table dimensions with dollies, refer to [Table 14-2, GT Table Dimensions with dollies..](#)

	Length		Width		Height		Weight	
	mm	in	mm	in	mm	in	kg	lb
GT1700V	2489	98	762	30	1143	45	576	1270
Lite Table	2244	89	820	32	1143	45	372	821

Table 14-2 GT Table Dimensions with dollies

Section 6.0: Console Delivery Considerations

The console is shipped without covers installed. The covers are delivered in the Product Grade Collector.

The dimensions of the console alone (as shipped) measure 832 mm (33 in.) deep, 470 mm (19 in.) wide, and 656 mm (26 in.) high.

Section 7.0: Storage Requirements



NOTICE Failure to adhere to storage requirements can result in equipment damage.

7.1 Short-term Storage (Less than Six Months)

If storing the CT system before installation for less than six months, store it in a temperature- and humidity-controlled warehouse. Protect it from weather, dirt, and dust. Meeting the following requirements prevents rust and corrosion from forming on bearing surfaces due to condensation:

- Storage temperature should not exceed 4° to 27° C (40° to 80° F).
- Maintain relative humidity (non-condensing) between 30% and 60%.
- Maximum rate of relative humidity change measures 5%/hr.
- Maximum rate of temperature change measures 3° C/hr. (5° F/hr.)
- Storage longer than 6 months is not recommended



NOTICE Between delivery qualifies as short-term storage. Van storage must meet the same specifications listed above.

7.2 Construction-Site Storage

When storing the CT system at a construction site be sure to adhere to the following storage requirements:

- Do not damage or puncture the shipping crate.
- Do not remove packaging until all construction is completed at the site and all dust created by the construction is removed.
- Maintain a storage temperature within the range of 10° to 32° C (50° to 90° F).
- Maintain a relative humidity (non-condensing) between 20% and 70%.

Section 8.0: Extreme Temperature Delivery and Storage



NOTICE Failure to adhere to extreme temperature requirements during delivery and storage can result in equipment damage.

Avoid extreme temperatures during system transportation and delivery.

Extreme temperatures consist of temperatures below -18° C (0° F), or above 49° C (120° F), without humidity control.

When transporting the CT system, prevent extended exposure of the system to temperatures or humidity outside of the following specifications:

- Temperature: -40° to +70° C (-40° to +158° F)
- Humidity: 5% to 95%



NOTICE Component freezing occurs when exposing the CT system to temperatures below -18° C (0° F) for a period longer than two (2) days. Allow a minimum of 12 hours for the CT system to adjust to ambient room temperature prior to installation.

This Page Intentionally Blank.

Chapter 15

Handling Requirements

Communicate the information in this chapter to any personnel who will transport, move, or otherwise handle the system components during transportation and delivery of the system.

Section 1.0: Transportation

To avoid dropping the gantry, it is recommended that the system is transported from GE Healthcare to the facility of the installation site, shipping dock-to-dock in a van. However, facilities without a loading dock may transport the system using liftgate or flatbed trucks, provided that no dropping or mis-handling of the system occurs. These methods involve unloading system components from the truck and then rolling them across SMOOTH sidewalks or other paved surfaces.

Section 2.0: Handling Requirements

The design of the system does not tolerate dropping, shock, vibration, tipping, or hoisting. Be sure to communicate these handling requirements to all parties involved in transporting, moving, and handling system components.

2.1 Avoid Dropping

Never drop the gantry, console, table, or PDU. A drop from a height greater than 13 mm (0.5 in.) may cause structural damage to the frame or other major components. Damage resulting from a drop (e.g., bent frame, misalignment) may not become apparent until after the system is installed.

2.2 Avoid Shocks and Vibrations

The design of the system, including the gantry, console, table, and PDU, does not tolerate excessive shock or vibration, which may occur during unloading. For example, rolling the console across a "washboard" style ramp may vibrate components, causing loose or broken connections. Damage resulting from shock or vibration (e.g., monitor, CD-ROM, hard-drive, or console failure) may not become evident until after the system is installed.

2.3 Avoid Tipping

All system components must remain upright at all times; avoid tipping them. Move the gantry by rolling it on its dollies ONLY, do NOT hoist it. Avoid tipping or lifting the gantry when moving it through hallways, doorways, elevators, etc.



NOTICE Never lift the gantry with a forklift. Lifting the gantry requires engineering approval for each occurrence. Your GE PMI should contact CT Engineering for all special lifting requirements, as unauthorized gantry lifting can cause gantry bearing damage.

2.4 Inclines and Flat-bed Truck Removal

Inclines and Flat-bed Truck Removalwrecker, attach the straps to the **LOWEST** possible point on the dolly, and lower the gantry at the **SLOWEST** reasonable rate, (see [Figure 15-1](#)).

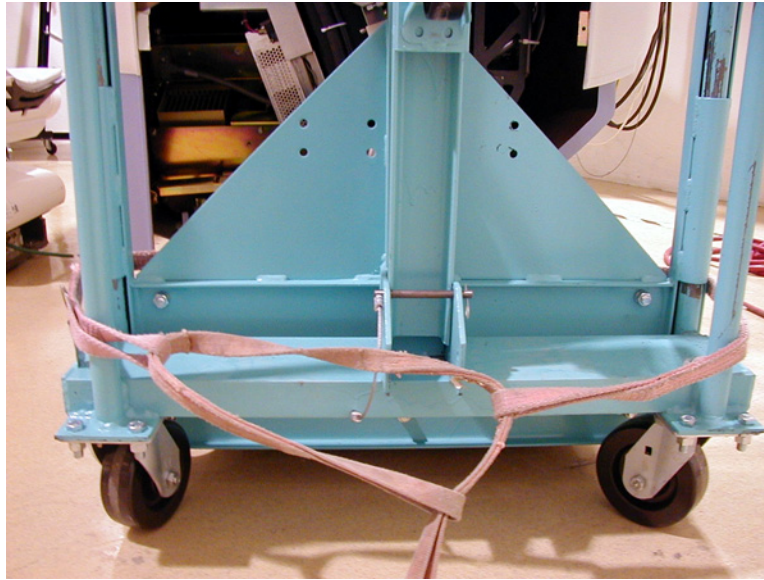

Figure 15-1 Proper Gantry Strap Location

 **WARNING** SOME ASSEMBLIES MAY BE TOP-HEAVY. BE CAREFUL NOT TO TIP!

© 2010, General Electric Company.
GE Medical Systems, a General Electric Company, going to market as GE Healthcare.
3000 N. Grandview Boulevard
Waukesha, Wisconsin 53188
USA

www.gehealthcare.com

